

Installation Guide

Submersible Wastewater Pumps, S-WP series

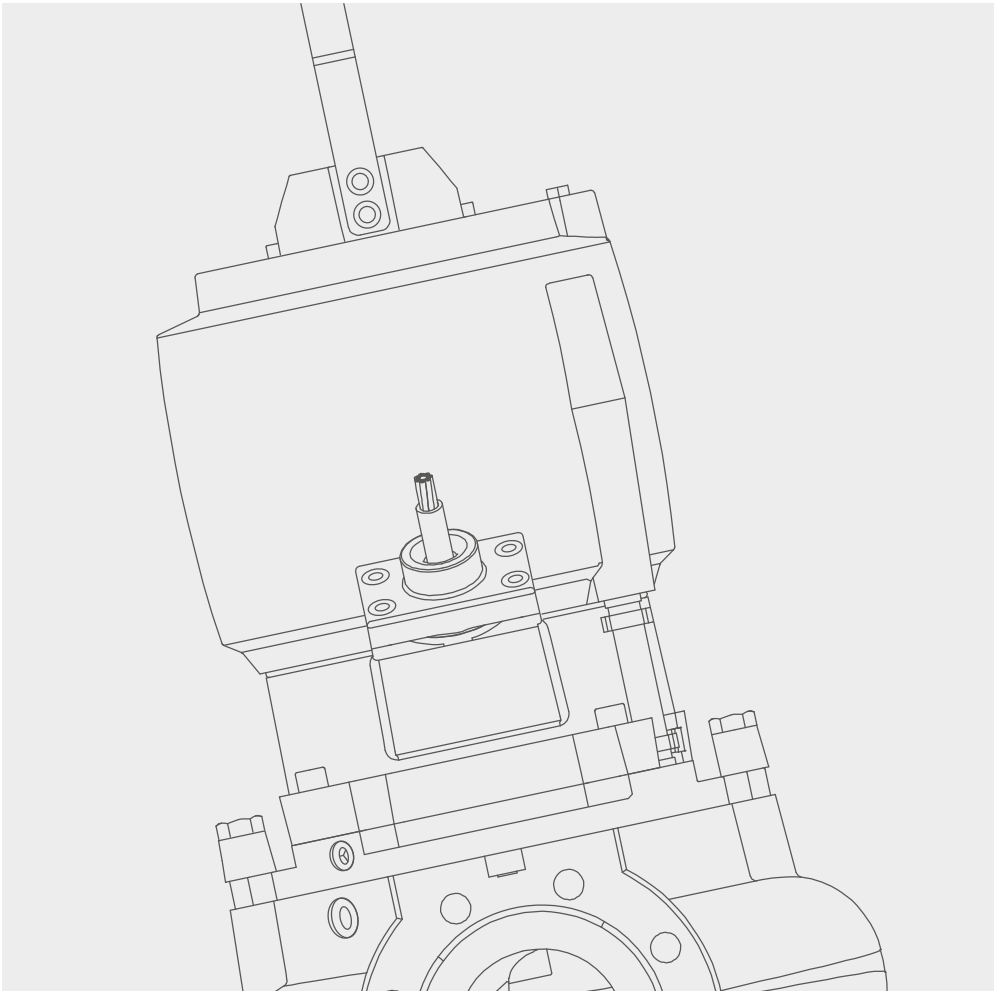

End-of-life, the pump must be recycled in accordance with local regulations.

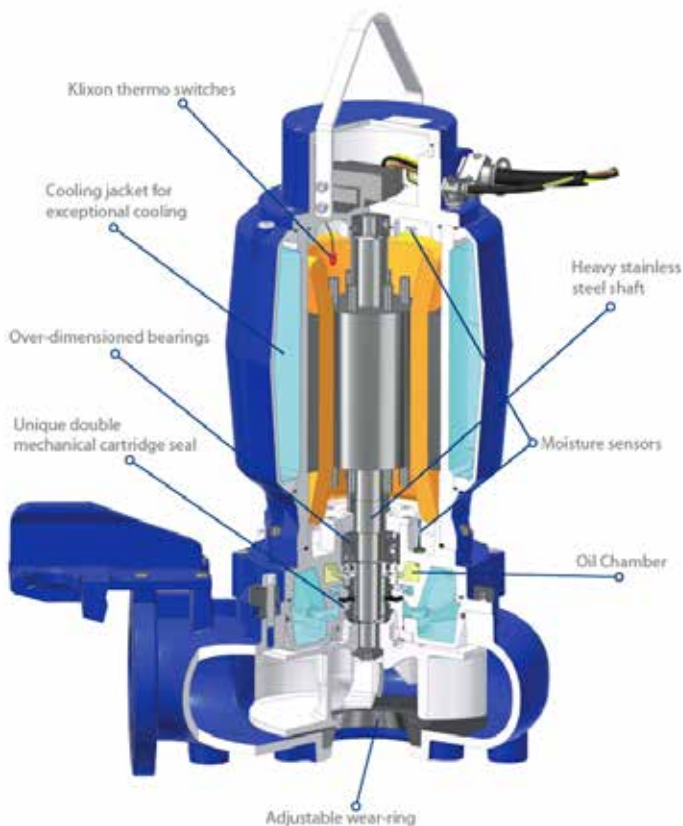

Table of Contents

1. General description	3
2. Technical Specification	4
3. Handling the Pump	7
4. Pump Installation	7
5. Electrical Installation	9
6. Operation.....	10
7. Service & Maintenance	10
8. Warranty.....	14
9. Pump Data.....	15
CE Declaration	23

Published by

DanPumps A/S
 Niels Bohrs Vej 10
 DK – 6100 Haderslev
 +45 30 73 81 96
 info@danpumps.dk

© DanPumps A/S 2023

Copyright

This document and its contents are subject to copyrights and other intellectual property rights owned by DanPumps A/S. No part of this document may be copied, re-produced or transmitted in any form or by any means, or for any purpose, without DanPumps's prior express written permission. Information and services provided in this document are made as a benefit and service to the user, and no representations or warranties are made about the accuracy or suitability of this information and these services for any purpose. All rights are reserved.

1. General Description

Pump label

DanPumps A/S		CE	
Nordager 25 DK-6000 Kolding			
Type			
No.			
Q		H	
l/min		P2	
V	PH	A	Hz
Kg	Class H	IP 68	▽ 20m
<small>- THERMALLY PROTECTED - SEE MANUAL FOR CORD REPLACEMENT - WARNING - DO NOT OPEN WHEN AN EXPLOSIVE ATMOSPHERE MAY BE PRESENT</small>			

Technical information is subject to change without notice.

Applications

This installation and service manual is only valid to the DanPumps S-WP series.

The S-WP series is manufactured in 5 different sizes: S-WP1, S-WP2, S-WP3, S-WP4 and S-WP5, and in 3 different applications: Wet-Pit, Dry-Pit and Portable.

The S-WP pump series are single-stage and non-self-priming pumps. The pumps are designed for pumping water, wastewater with pollutants, and low-viscosity types of sludge. They can also be used as drainage pumps where sand and gravel occur. The impeller design allows each individual impeller to be trimmed to your exact performance requirements.



WARNING

If the location has hazardous media - ensure the pump has been delivered with the correct approval.

Local fire risks restrictions must be obeyed at all time.

The pump meets the EU's machine directive, find the declaration of conformity at the back of this manual.

DanPumps A/S guarantees that the pumps' airborne noise level does not exceed a noise level between 70 to 74 dB (at normal operation).



WARNING

If people can get physical contact with the pump or the fluid being pumped at e.g. open excavations, building sites or the like, a fault circuit-breaker (HFI or HPFI) must be mounted in the electrical installation.

If the pump is used in oceans, lakes etc. there must be a minimum safety distance of 20 meters between the pump and any persons in the water.

National and local standards have to be observed at all times.

2. Technical Specification

The S-WP pumps have a built-in motor in a 3-phased version for either

- 50 Hz (230/400 V or 400/690 V) or
- 60 Hz (220 V, 460 V or 575/1000 V).

Please see the motor label for accurate information regarding this pump.

Ambient temperature and media up to max. +75°C.

The motor is CE-marked according to the Low Voltage Directive 2006/95/EC.

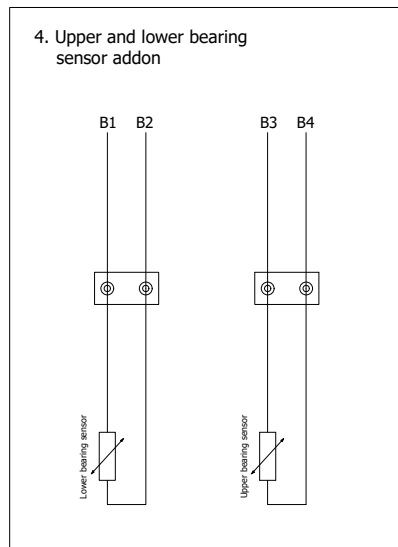
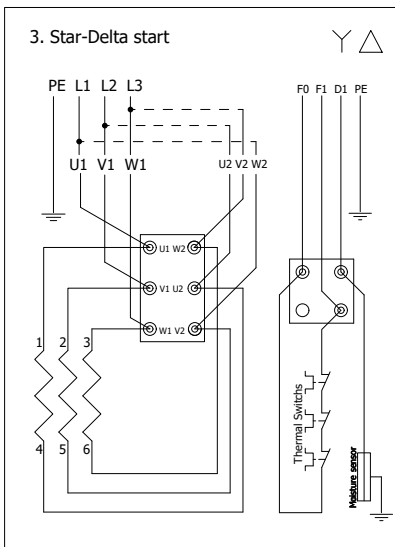
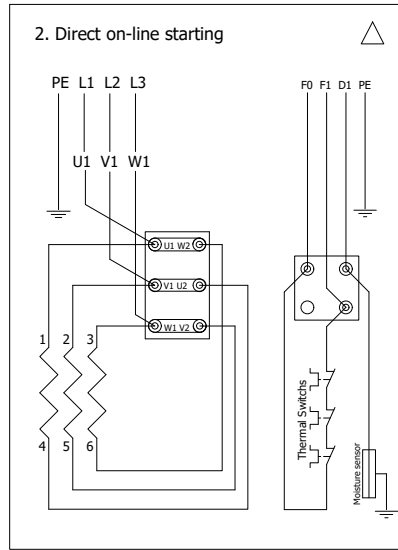
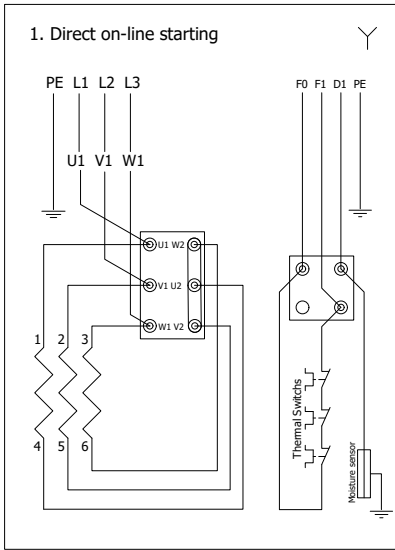

2.1 Motor Protection

The degree of protection is standard IP68, and the insulation class is F (class H as option). Made according to standard EN 60204-1.

The electromotor has a thermal protection switch build-in. The thermal switches open at 150°C and close at 90°C. Automatic restart.

The terminals for the thermal protection switch are F0 & F1.



Absent the use of this warranty is voided.

2.2 Moisture Protection

The pumps are as standard, supplied with a moisture sensor; that detects moisture in the stator compartment and the oil chamber compartment simultaneously.

The terminals for moisture protection are D1 (D1 to ground).

The conductor must be connected to an external moisture relay installed in the main control box. The relay will cut off or signal (depending on the connection) that the pump has moisture or water infiltration.

The standard alarm level is 100 kΩ for submersed wet-pit and dry-pit installation.

The voltage of 24V DC. Moisture relays (10519004/05/06) are available as an option at DanPumps A/S.



Absent the use of this warranty is voided.

2.3 Motor Cable

The pumps are standard equipped with 10 m electric cable of the type H07RN-F preassembled. The pumps can be delivered with either; one cable for both power and control, or two cables: one for the

main power supply and one for the control cable. For installation of a longer cable please contact your local DanPumps dealer, who can advise you on volt drop and dimensions. Please note that cable type and the number of cables can vary depending on voltage, start method and country restrictions. The conductors in the main cable are marked L1, L2, L3 + PE for ground. *Please see drawings 1, 2 and 3 on page 4.*

2.4 Cooling System

An internal cooling jacket for cooling the motor is standard on dry pit and portable installations and optionally for wet pit installations.

The cooling jacket is a closed cooling circuit system, that does not clog or lose its function due to polluted water.

Amount of cooling fluid, please see table. (30% Propylene glycol DOWCAL® 30 + 70% water). *(Find table on page 6)*

2.5 Pump Material

- **Pump housing (volut):**
Gray cast iron GJL-250 (GG25).
Stainless steel AISI 316 as an option
- **Pump impeller:**
Ductile cast iron GJS-400-15 (GGG-40)
Stainless steel AISI 316 as an option
- **Pump shaft:**
Stainless cast steel W. Nr. 1.4057 / AISI 431
- **O-rings:**
Nitrile / NBR
- **Seal type:**
(After specification)

2.6 Scope of Delivery

The pumps for wet pit installations are delivered as standard without DCB, UGB and guide pipes. DCB and UGB must be ordered separately. The pump is delivered without a moisture relay. Relay (10519004/05/06) is available as an option. *Your local DanPumps dealer can supply you with the correct relay.*

Amount of Liquid in Liters:

Model	S-WP1	S-WP2	S-WP3	S-WP4	S-WP5
Without cooling jacket	0.5	1.3	3.5	5.5	14
With cooling jacket	2.9	5.7	11	44	134
Seal cooling oil	0.32	0.45	0.15	0.4	0.4

Pump Curves - 50 Hz

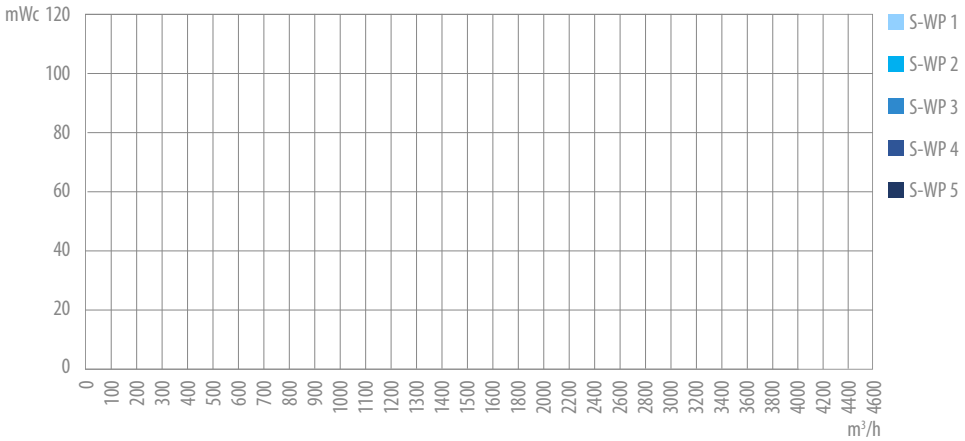

Pump Curves - 60 Hz

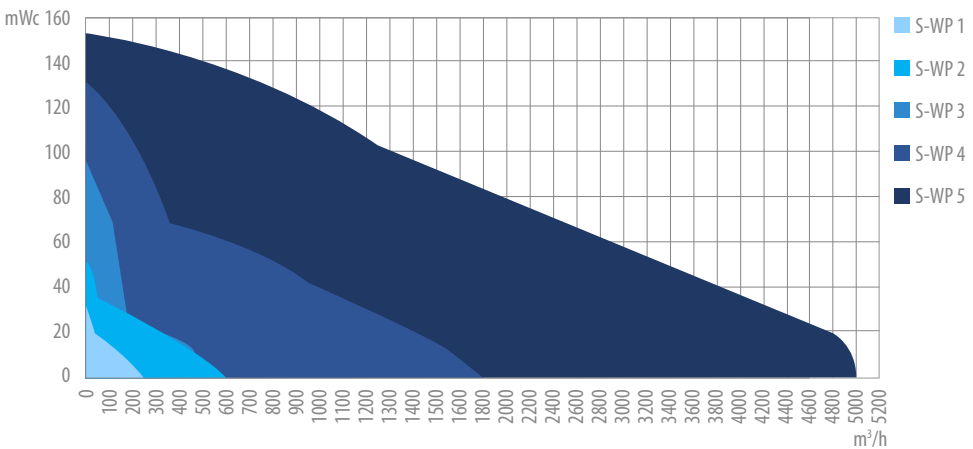

3. Handling the Pump

The pump must be packaged properly during transport to avoid damage to the pump or its surroundings. It can be transported and/or stored in a vertical or horizontal position.

Always place the pump on a stable surface, to avoid the pump from moving or tipping during service, transport, testing and installation.

After storing, for a long period, the pump must be inspected carefully before use.

Rotate the impeller by hand, to ensure the correct friction of the mechanical seal. Ensure the electrical connections are dismantled.

Accidents in relation to installation can be mini-

mized by taking care. Take especially care with the heavyweight of the pump and the risk of electrical accidents.

When lifting with hoisting equipment, these must always be of the correct dimensions, with consideration to the lifted weight.



WARNING

Never walk under hanging loads.

Never lift or tow the pump in the cable.

Never get entangled in pump cables and lifting chains.

4. Pump Installation

The immersion depth for pumps covered by this manual is max. 20 meters. The temperature of the pumped media must not continuously exceed +45°C.

Cavitation may occur, if the pump intake becomes obstructed or if the NPSH value is too low, causing damage to the internal elements of the pump.

Always provide the right suction conditions for the pump.

Accidents in relation to installation can be minimized by taking special care. Be especially careful with the pump's weight and the risk of electrical accidents.

When lifting with hoisting equipment, these must always be designed to fully accommodate the weight of the complete pump units. Never get entangled in the pump cables and lifting chains.

Wet-Pit Installation with Submerged Pump on DCB

- Install the cables for the pump in such a way that they avoid any sharp bends, getting compressed and cannot be sucked into the pump.
- Mount the Discharge Connection Bracket (DCB) firmly onto the bottom of the well with expanding bolts.
- When mounting the Upper Guide Brackets (UGB), the guide tubes must be vertical and parallel.
- Connect the discharge pipe to the DCB flange. We recommend mounting a non-return check valve on the discharge pipe.
- The hoisting device must be installed directly above the pump's centre of gravity. The pump will then automatically connect at the bottom position on the DCB and loosen again when lifted. (Cooling jacket is an option).

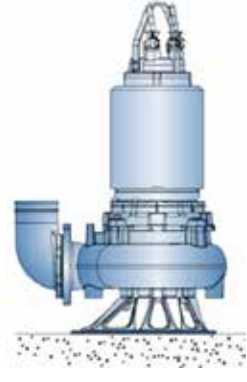
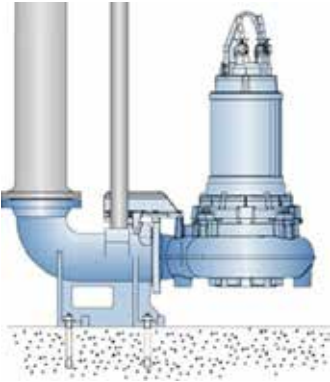

- Always check the discharge pipe dimension according to the required m^3/h capacity.

Dry-Pit Installation with Submerged Pump on Legs

- Install the cables for the pump in such a way that they avoid any sharp bends, getting compressed and cannot be sucked into the pump.
- The pump is delivered with support legs.
- The pump must be mounted on a solid surface, and the foundation/base must have sufficient strength to support the pump.
- The legs are adjustable; the height is regulated by loosening the two bolts on each leg and tightening them again at the desired height. The pump volute is predrilled for a standard DN flange.
- Then mount the inlet and discharge pipes. (Suction elbows can be supplied).
- We recommend mounting a ball valve on the suction side, and a ball valve + a non-return check valve on the discharge side.
- Always check the discharge pipe dimension according to the required m^3/h capacity.

- It is also important that there is no pulling/towing in the cables or discharge hoses.
- The pump must be mounted in a vertical position on a solid surface, so it does not tip over or “dig” into the sand, sludge etc.
- Please note that the inlet of the pump is exposed, all physical contact must be avoided. Keep a minimum safety distance of 5 meters from a pump in operation.
- The pump is capable of giving a very powerful suction underwater. Never underestimate this.
- If necessary, mount a filter plate onto the pump’s frame to avoid large objects being sucked into the pump.

Discharge Info for all 3 Installations

To reduce load and power dissipation, we recommend use of pipes with the same (DN) or larger diameter than the pump discharge. Connection elements that may cause air pockets should not be used under any circumstances.

The diameter of the pipes used, ought to be such, which ensures the water speed remains below 2 m/s (7 ft per second).

If a problem occurs, please contact your local DanPumps dealer.

Portable Installation

- When mounting this installation type, the cables must be installed so that they do not bend, get damaged by vehicles etc.

5. Electrical Installation

Motors can be used with a power supply deviation of $\pm 5\%$ voltage and $\pm 2\%$ frequency, according to IEC60034-1.

Connections must be made to ensure permanently safe electrical connection is maintained, both for the main supply and the earth connection. A ground-fault circuit breaker is necessary.

The electric board must be equipped with a motor guard that fits the motor size.

The relay must be set as follows for a direct or star-delta start:



WARNING

Electrical work is only permitted to be carried out by qualified specialists and must be carried out in accordance with local regulations. Let only an authorized electrician do this job.



Before work commences, ensure that all power is switched off and cannot be switched on again. Check that supply voltage and frequency are the same as rated data on the pump.

Direct Start

The motor guard is set to the current (measured in ampere) stated on the identification plate. When the thermal surveillance is connected, the motor guard's setting is increased by 10%.

Star-Delta Start

The motor guard is set to the current (measured in ampere) that is stated on the identification plate multiplied by 0.58. When the thermal overload switches are connected add 8% to the calculated value. The grid must be secured with ordinary safety cutouts.

Thermal Protection

All pumps are equipped, with thermal overload switches built into the stator.

These are marked F0 & F1. The thermal protection conductors must be connected in series within the motor guard in the external control board. If this protection is not connected the warranty will be void in case of damage. See also the technical specification.

Moisture Sensor

The conductor marked "D1" (Please see drawings on page 4) is connected to two moisture sensors, one located in the oil housing and the other located in the terminal housing. These sensors must be connected to a relay in the external control panel.

If moisture is detected in the oil or terminal housing, the moisture relay is switched off.

Your local DanPumps dealer can supply you with the correct relay as an option.

6. Operation

Before start-up, the pump must be fully assembled and ready for operation, and this manual must be read thoroughly. Always check the direction of rotation before starting the pump.

During start-up, the motor's starting torque may cause the pump to jerk in counter-clockwise direction, but normal operation will be in clockwise direction. The pumps must always rotate clockwise. If it rotates counter-clockwise, swap two phases in the external control box.

Never start the pump without impellers; the pump must be fully assembled and ready for operation.

Do not start the pump if the cables are not fully

connected or if the overload switches and leakage sensor are not operational.

This work must only be carried out by a licensed electrician.



WARNING

The starting torque can be very powerful even by small pumps. Never hold on to the pump and never start the pump when hanging free.

Place the pump on a stable surface, to avoid the pump from moving or tipping during start-up.

7. Service & Maintenance

Before any inspection, service or repair of the pump, it has to be physically disconnected from the electrical power supply. Remove connectors or dismount the wires on the electric board.

(Any emergency stop can be released or be defective and start the pump by mistake)

- All pumps require regular control and preventive maintenance to operate economically and reliably.
- The pump should be checked every 6 months and during possible extreme operating conditions more often. Contact an authorized DanPumps workshop or your local DanPumps dealer, for a complete inspection of the pump.
- Clean the pump carefully before dismantling it.
- Follow local and national safety instructions.

Type W - Wet Pit Installation

Installed on a guide rail system, with a quick-release discharge connection bracket (DCB). The DCB is bolted to the floor of the tank/well. The volute is equipped with an adapter to guide the pump via two 2" or 2 1/2" guide rails, to secure connection on the DCB.

Type D - Dry Pit Installation

Installed in a dry well. The pump has a factory mounted adjustable stand. The height of the stand makes it possible to install a standard suction elbow. The pump volute is predrilled for a standard DN flange.

Type P - Portable or Fixed Installation

This pump model is suitable for temporary or per-

manent installations. The pump is equipped with a steel foot stand and is built with a threaded (BSP) or just plain hose connection.

The Volute

The volutes are equipped with adjustable wear rings as standard.

The volute has between 2 or 6 pcs. fast lock latches for easy release between the motor unit and volute.

Lift the pump from the sump and clean thoroughly. Loosen the latches and lift the motor unit out from the volute.

Changing Oil

Remove the inlet and outlet plugs. Tilt the pump against the outlet and discharge used oil according to local regulations. See technical specification for oil amount.

If there is any problem filling in oil, tilt the pump slightly so that air can escape.

Inspect the motor housing by removing the screw marked "motor". Tilt the pump slightly. If water, oil or other debris is present in the motor housing, a full dismantling is required.



NOTE:

Do not forget to tighten plugs after filling.

Changing Cooling Liquid

Remove the cooling liquid plug on the cooling flange (water out). Open the plugs on top of the cooling jacket. Replug the water outlet. Slowly fill the new cooling liquid into the water inlet on top of the cooling jacket. See technical specification for cooling liquid amount.



NOTE:

Do not forget to tighten plugs after filling.



Fast lock latch bolt



Seal cartridge

Disassembling the impeller

The impeller is fixed to the shaft with a washer and a screw. Secure the impeller and remove the impeller bolt with a wrench.

Disassembling the Seal Cartridge

Disassemble the volute and impeller as described, and then drain the motor for cooling liquid and oil. Place the rotating element on its side.

Remove the four screws that hold the seal cartridge. The cartridge can be removed from the oil chamber by inserting the screws into the "jacking holes" in the cartridge, which will force the cartridge from the housing.

Disassembling the Enclosure Cover

Remove the screws fixing the cover. Gently lift the cover to gain access to the terminal board area. Be careful not to damage the cable and motor

connections. If any wires are disconnected, then ensure to reinstall them correctly again.

Disassembling the Terminal Housing

Disconnect all wires from the terminal board. The terminals are spring operated and can be opened by a screwdriver. Open the cable glands for wiring to the stator. Remove the screws and lift the terminal housing carefully. Do not damage the wires to the stator.

Disassembling the Cooling Jacket

Drain out the cooling water. Disassemble by lifting off the cooling jacket. Inspect where the O-rings are located and clean if necessary.

Check the Stator Unit

If the motor protection trips repeatedly, the stator must be inspected. Disassemble the terminal housing cover.

Disconnect the stator wires (spring terminals). Check the insulation resistance with min. 500V insulation tester. Test between U1, V1 and W1 to GND.

Test between U1, V1 and W1. The insulation resistance must exceed 1 mega ohm. If the insulation resistance is less than 1 mega ohm, the stator must be cleaned and dried in an oven for 2-3 hours at 100°C.

Check the circuit of the three built-in thermal overload switches using a buzzer or other measuring device.

Before reconnecting:

Check the motor cable has no broken wires. Check the motor cable insulation with a 500V insulation tester, between the wires.

Removal of the Stator Housing

Mark the stator housing position on the bearing house to reinstall correctly. Remove the six screws fixing the stator casing. Lift the stator casing approx 5 cm from the shaft and rotor - use a hoist. Discon-

nect the wire from the moisture sensor. Continue lifting off the stator housing.

Disassembling the Rotor and Bearings

Remove the stator housing as described above, and lift the shaft with the rotor and bearing out. (Lower bearing will stay in the lower bearing house).

Always replace damaged bearings and bearings that have been in contact with water.

Assembling

Clean the O-ring grooves and contact surfaces carefully. If necessary use a wire brush. Replace all O-rings. Lubricate all O-rings with oil or grease to prevent the O-rings from getting stuck or damaged when remounted. Also, lubricate the threads on the screws to facilitate disassembling when servicing next time.

Mounting the Bearings

Check that the shaft is straight and the keyway is not damaged.

Polish scratches and burrs off. Push the upper bearing into place. If a press is needed, then put pressure only on the inner ring of the bearing, using a piece of pipe and a soft hammer.

Put the shaft through the shaft hole in the bearing house. Mount the lower bearing from the bottom side of the bearing house. The lower bearing is a double bearing. Ensure that the bearings are placed face to face. *Please see the picture.* Remember to lubricate the bearings, if the bearings aren't standard closed with caps (2RS).

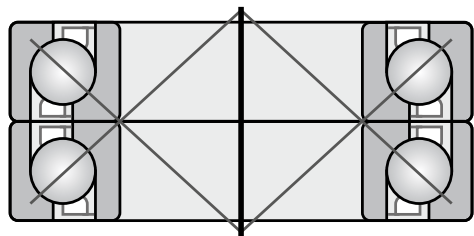

Mounting the Seal Cartridge

Put down the motor unit. Lubricate the shaft and all four O-rings on the seal unit (three external on the seal housing, and one internal in the seal sleeve). Carefully push the seal unit onto the shaft, and place it in position by aligning the screw holes. Do not use hard striking tools. Tighten the seal unit by fastening the four screws. All four screws must be tightened concurrently to ensure that the sealing unit does not tilt.



NOTE:

Never run the motor without having the impeller mounted if the seal is mounted. As it will cause damage to the O-rings in the seal, and it is also a danger to your safety.

Changing the Cable

Always replace a damaged cable. Connecting the pump with a defective cable can be life-threatening. Never extend a cable, always use full-length cables as water can enter the motor and damage it.

Avoid water entering the pump when replacing the cable:

- The cable gasket of rubber and the cable washers must fit the cable dimension perfectly.
- The outer diameter of the cable must not be deformed. Always cut away a piece at the cable entry to ensure that it will seal in case of a recycled cable.

Use a lubricant to facilitate the connection of the cable.



NOTE:

The grounded conductor must be longer in the pump than the line conductors. The ground wire will then be the last one to be torn off in the event of an accident.

Mounting the Impeller

Turn the shaft so the keyway is upward. Put the key in its groove and push the impeller onto the shaft. Lock the impeller to prevent it from rotating with a pipe or similar equipment and fasten the impeller washer and screw.

Always use loctite when tightening the impeller bolt.

Mounting the Stator

Erect the oil housing and clean all contact surfaces between the oil housing and the stator unit with a wire brush. Lubricate and mount a new O-ring on the oil housing. The stator is now ready to be mounted on the oil housing. Lift the stator unit with a lifting device and lower it carefully over the rotor. Ensure that the rotor does not damage the windings or the stator stack. Remember to connect the wire from the moisture sensor. Fasten the stator with its four screws. Make sure that the external markings are in line.

Mounting the Cooling Jacket

Put the gasket on top of the stator house. Fit the two external cooling tubes. Make sure that the O-rings are changed. Lower the cooling jacket over the stator house and ensure that the external markings are in line and the cooling pipes are in the right position. Fasten the cooling jacket with four screws.

Mounting the Motor Unit in the Volute

Turn the latch bolts so that the driving unit runs free down to the upper edge of the volute. Turn the latch bolts in and fasten the screws alternately. Ensure that the external markings are in line. Use a wrench to tighten by hand.

Adjusting the Wear Ring

Place the pump on the side and measure the clearance between the impeller and the wear ring. The clearance should be max. 0.4 mm. The wear ring is placed at the bottom of the volute. Loosen the three horizontal screws and adjust with the three vertical screws. If necessary, strike carefully

with a hammer or plastic club. Tighten the screws after the adjustment.

If using a vortex impeller, there is no need to adjust the wear ring!

Tightening Torque Screws

Size (Nm)

M6:	7
M8:	17
M10:	33
M12:	57
M14:	91
M16:	140
M20:	275

Tightening Cable Gland

No specific tightening torque can be provided for cable glands. Tighten until the torque is tight, and the rubber offers good resistance. Finish with one extra complete rotation for each screw.

8. Warranty

Comprehensive and Global 1-year Warranty Included in Pump Sales Price

All DanPumps products come with a 1-year warranty that fully complies with legal requirements.

The warranty covers product and material defects which are not the results of normal wear and tear for a period of 12 months from the date of delivery. The warranty period may not, however, exceed 30 months from the date of production.

Warranty Claims will be Rejected in the Following Situations:

- If the defect in the product arises from:
 - any drawing, design or specification supplied by the customer/purchaser
 - Modifications undertaken by the customer purchaser or a third party without the consent of DanPumps
- If a defect is caused by:
 - normal wear and tear
 - inadequate maintenance or faulty repair by unauthorized technician

- failure to observe the operating instructions
- over-loading
- use of any unsuitable material
- the effects of chemical or electrolytic action
- building or assembly work not undertaken by authorized technician
- other reasons beyond DanPumps' control

As a general rule, DanPumps will not accept to pay transportation/replacement/installation costs for faulty products.

Warranty claims may be submitted by contacting the local DanPumps sales company or the point of sale.

Benefit:

- Knowledge that DanPumps backs its products with clearly defined warranty terms
- Warranty claims with well-defined contacts and short response time

9. Pump Data – 50 Hz

Type	kW P2	Rpm	I (A)		Cable DOL		Cable S/D		Oil	Coolant (w/o Cooling packet)	Weight in kg Wet install	Weight in kg Dry install	Weight in kg Portable install	Throughlet in mm	Outlet flange
			230V	400V	3x230V	3x400V	3x230V	3x400V							
WP0-37-2	0.55	2850	3.5	1.4	3x1.5	4x1.5	NA	NA	0.6	NA	14	NA	14	36	R1½"
WP0-50-2 1.p	0.8	2850	5.8	-	3x1.5	-	-	-	0.3	NA	22	NA	22	45	R2"
WP0-50-2	0.8	2850	5.8	2.2	3x1.5	4x1.5	NA	NA	0.3	NA	22	NA	22	45	R2"
WP1-65-4	1.1	1430	5.9	3.0	4x1.5/7x1.5	4x1.5/7x1.5	NA	NA	0.4	NA	32	NA	33	55	R2½"
WP1-65-2	1.85	2850	7.0	4.0	4x1.5/7x1.5	4x1.5/7x1.5	NA	NA	0.4	NA	33	NA	34	55	R2½"
WP1-65-2	2.2	2850	9.4	5.5	4x1.5/7x1.5	4x1.5/7x1.5	NA	NA	0.4	NA	40	NA	41	55	R2½"
WP1-70-2	1.5	2890	5.9	3.4	7x1.5	7x1.5	12x1.5	12x1.5	0.3	2.9(0.5)	95	102	104	60	DN80
WP1-70-2	2.2	2890	8.2	4.7	7x1.5	7x1.5	12x1.5	12x1.5	0.32	2.9(0.5)	95	102	104	60	DN80
WP1-70-2	3	2920	10.7	6.1	7x1.5	7x1.5	12x1.5	12x1.5	0.32	2.9(0.5)	95	102	104	60	DN80
WP1-70-2	3.5	2920	10.7	6.1	7x1.5	7x1.5	12x1.5	12x1.5	0.32	2.9(0.5)	95	102	104	60	DN80
WP1-80-4	1.1	1430	4.8	2.8	7x1.5	7x1.5	12x1.5	12x1.5	0.32	2.9(0.5)	92	100	102	70	DN100
WP1-80-4	1.5	1430	6.3	3.6	7x1.5	7x1.5	12x1.5	12x1.5	0.32	2.9(0.5)	92	100	102	70	DN100
WP1-80-4	2	1460	NA	4.8	7x1.5	7x1.5	12x1.5	12x1.5	0.32	2.9(0.5)	92	100	102	70	DN100
WP1-80-4	2.5	1460	11.3	6.5	7x1.5	7x1.5	12x1.5	12x1.5	0.32	2.9(0.5)	92	100	102	70	DN100
WP1-80-4	3	1460	11.3	6.5	7x1.5	7x1.5	12x1.5	12x1.5	0.32	2.9(0.5)	92	100	102	70	DN100
WP2-80-2	6.5	2900	26.7	15.4	7x2.5	7x1.5	12x1.5	12x1.5	0.45	5.7(1.3)	148	150	150	70	DN80
WP2-80-2	9	2930	37.0	21.3	NA	7x2.5	NA	12x1.5	0.45	5.7(1.3)	151	153	154	70	DN80
WP2-80-2	11	2930	37.4	21.5	NA	7x2.5	NA	12x1.5	0.45	5.7(1.3)	151	153	154	70	DN80
WP2-100-6	2.5	970	9.0	5.1	7x1.5	7x1.5	12x1.5	12x1.5	0.45	5.7(1.3)	142	144	144	100	DN100
WP2-100-6	5.5	970	22.1	12.7	7x2.5	7x1.5	NA	12x1.5	0.45	5.7(1.3)	143	145	145	100	DN100
WP2-100-4	4	1460	16.9	9.7	7x1.5	7x1.5	12x1.5	12x1.5	0.45	5.7(1.3)	143	145	145	100	DN100
WP2-100-4	6	1460	25.3	14.5	7x2.5	7x1.5	12x1.5	12x1.5	0.45	5.7(1.3)	151	153	153	100	DN100
WP2-100-4	7.5	1475	27.3	15.7	NA	7x2.5	NA	12x1.5	0.45	5.7(1.3)	157	159	159	100	DN100
WP2-100-4	9	1475	37	21.3	NA	7x2.5	NA	12x1.5	0.45	5.7(1.3)	159	161	161	100	DN100
WP2-100-4	11	2930	37.4	21.5	NA	7x2.5	NA	12x1.5	0.45	5.7(1.3)	163	165	165	100	DN100
WP2-150-6	2.5	970	9.0	5.1	7x1.5	7x1.5	7x1.5	7x1.5	0.45	5.7(1.3)	156	158	158	100	DN150
WP2-150-6	5.5	970	22.1	12.7	NA	7x1.5	NA	7x1.5	0.45	5.7(1.3)	159	161	161	100	DN150
WP2-150-4	4	1440	16.9	9.7	7x1.5	7x1.5	12x1.5	12x1.5	0.45	5.7(1.3)	148	150	150	100	DN150
WP2-150-4	6	1460	25.3	14.5	7x2.5	7x1.5	12x1.5	12x1.5	0.45	5.7(1.3)	159	161	161	100	DN150
WP2-150-4	7.5	1475	27.3	15.7	NA	7x2.5	NA	7x2.5	0.45	5.7(1.3)	159	161	161	100	DN150
WP2-150-4	9	1475	37.4	21.5	NA	7x2.5	NA	7x2.5	0.45	5.7(1.3)	159	161	161	100	DN150
WP2-150-4	11	2930	37.4	21.5	NA	7x2.5	NA	12x1.5	0.45	5.7(1.3)	163	165	165	100	DN150
WP2-150-4	7.5	2930	25.0	14.4	4x1.5 + 4x4	7x1.5	4x1.5 + 4x4	4x1.5 + 7x1.5	0.15	11(3.5)	205	207	207	70	DN100
WP3-80-2	9	2930	37.4	21.5	4x1.5 + 4x10	4x1.5 + 4x4	4x1.5 + 4x10	4x1.5 + 4x4	0.15	11(3.5)	219	221	221	70	DN100
WP3-80-2	12.5	2930	47.1	27.1	4x1.5 + 4x10	7x2.5	4x1.5 + 4x10	12x1.5	0.15	11(3.5)	252	254	254	70	DN100
WP3-80-2	18.5	2930	71.0	41.0	4x1.5 + 2(4x6)	4x1.5 + 4x10	4x1.5 + 2(4x6)	4x1.5 + 4x10	0.15	11(3.5)	252	254	254	70	DN100
WP3-80-2	22	2930	72.0	41.0	4x1.5 + 2(4x6)	4x1.5 + 4x10	4x1.5 + 2(4x6)	4x1.5 + 4x10	0.15	11(3.5)	252	254	254	70	DN100
WP3-80-2	25	2930	71.0	41.0	4x1.5 + 2(4x6)	4x1.5 + 4x10	4x1.5 + 2(4x6)	4x1.5 + 4x10	0.15	11(3.5)	253	255	255	70	DN100
WP3-100-6	6.6	970	22.1	12.7	4x1.5 + 4x4	7x1.5	4x1.5 + 4x4	12x1.5	0.15	11(3.5)	201	203	207	100	DN100
WP3-100-6	11.5	970	43.7	25.0	4x1.5 + 4x10	4x1.5 + 4x4	4x1.5 + 4x10	4x1.5 + 4x4	0.15	11(3.5)	225	227	232	100	DN100
WP3-100-4	7.5	1475	30.7	17.6	4x1.5 + 4x4	7x1.5	4x1.5 + 7x2.5	12x1.5	0.15	11(3.5)	201	203	207	100	DN100
WP3-100-4	9	1475	36.8	21.2	4x1.5 + 4x6	7x2.5	4x1.5 + 7x2.5	12x1.5	0.15	11(3.5)	204	206	211	100	DN100
WP3-100-4	12.5	1460	49.3	28.4	4x1.5 + 4x10	4x1.5 + 4x4	4x1.5 + 2(4x4)	12x1.5	0.15	11(3.5)	225	227	232	100	DN100
WP3-100-4	17	1460	66.3	38.1	4x1.5 + 4x10	4x1.5 + 4x6	4x1.5 + 2(4x6)	4x1.5 + 7x2.5	0.15	11(3.5)	241	243	247	100	DN100
WP3-100-4	18.5	1475	68.0	39.1	4x1.5 + 2(4x6)	4x1.5 + 4x10	4x1.5 + 2(4x6)	4x1.5 + 4x10	0.15	11(3.5)	241	243	247	100	DN100
WP3-100-4	22	1455	87.9	50.5	4x1.5 + 2(4x10)	4x1.5 + 4x10	4x1.5 + 2(4x10)	4x1.5 + 2(4x4)	0.15	11(3.5)	246	247	250	100	DN100
WP3-150-6	6.6	950	30.0	17.2	4x1.5 + 4x4	7x1.5	12x1.5	12x1.5	0.15	11(3.5)	223	225	235	100	DN150
WP3-150-6	11.5	970	43.7	25.0	4x1.5 + 4x10	4x1.5 + 4x4	4x1.5 + 4x10	4x1.5 + 4x4	0.15	11(3.5)	270	272	282	100	DN150
WP3-150-4	7.5	1455	30.7	17.6	4x1.5 + 4x4	7x1.5	4x1.5 + 7x2.5	12x1.5	0.15	11(3.5)	215	217	227	100	DN150
WP3-150-4	9	1455	36.8	21.2	4x1.5 + 4x6	7x2.5	4x1.5 + 7x2.5	12x1.5	0.15	11(3.5)	217	219	229	100	DN150
WP3-150-4	12.5	1460	49.3	28.4	4x1.5 + 4x10	4x1.5 + 4x4	4x1.5 + 2(4x4)	12x1.5	0.15	11(3.5)	238	240	250	100	DN150
WP3-150-4	17	1460	66.3	38.1	4x1.5 + 4x10	4x1.5 + 4x6	4x1.5 + 2(4x6)	4x1.5 + 7x2.5	0.15	11(3.5)	255	257	267	100	DN150
WP3-150-4	18.5	1475	68.0	39.1	4x1.5 + 2(4x6)	4x1.5 + 4x10	4x1.5 + 2(4x6)	4x1.5 + 4x10	0.15	11(3.5)	255	257	267	100	DN150

Type	kW P2	Rpm	I (A)		Cable DOL		Cable S/D		Oil	Coolant (w/o Cooling jacket)	Weight in kg Wet install	Weight in kg Dry install	Weight in kg Portable install	Throughlet in mm	Outlet flange
			230V	400V	3x230V	3x400V	3x230V	3x400V							
WP3-150-4	22	1475	87.9	50.5	4x1.5 + 2(4x10)	4x1.5 + 4x10	4x1.5 + 2(4x10)	4x1.5 + 2(4x4)	0.15	11(3.5)	259	262	270	100	DN150
WP4-100-4	18.5	1465	71.4	41.0	4x1.5 + 4x16	4x1.5 + 4x6	4x1.5 + 2(4x10)	4x1.5 + 7x2.5	0.4	44(5.5)	443	593	474	80	DN100
WP4-100-4	22	1465	83.9	48.2	4x1.5 + 4x25	4x1.5 + 4x10	4x1.5 + 2(4x10)	4x1.5 + 2(4x4)	0.4	44(5.5)	453	603	484	80	DN100
WP4-100-4	30	1465	118.7	68.3	4x1.5 + 4x35	4x1.5 + 4x16	4x1.5 + 2(4x16)	4x1.5 + 2(4x6)	0.4	44(5.5)	499	626	510	80	DN100
WP4-100-4	37	1465	141.2	81.2	4x1.5 + 2(4x25)	4x1.5 + 4x16	4x1.5 + 2(4x25)	4x1.5 + 2(4x10)	0.4	44(5.5)	549	674	560	80	DN100
WP4-100-4	45	1465	171.7	98.8	4x1.5 + 2(4x25)	4x1.5 + 4x25	4x1.5 + 2(4x35)	4x1.5 + 2(4x10)	0.4	44(5.5)	592	717	603	80	DN100
WP4-100-4	55	1465	201.7	116.0	4x1.5 + 2(4x35)	4x1.5 + 4x35	4x1.5 + 2(4x35)	4x1.5 + 2(4x16)	0.4	44(5.5)	604	729	615	80	DN100
WP4-100-4	65	1475	238.3	137.0	NA	4x1.5 + 2(4x25)	4x1.5 + 2(4x35)	4x1.5 + 2(4x25)	0.4	44(5.5)	604	729	615	80	DN100
WP4-150-4	18.5	1465	71.4	41.0	4x1.5 + 4x16	4x1.5 + 4x6	4x1.5 + 2(4x10)	4x1.5 + 7x2.5	0.4	44(5.5)	466	573	475	100	DN150
WP4-150-4	22	1465	83.9	48.2	4x1.5 + 4x25	4x1.5 + 4x10	4x1.5 + 2(4x10)	4x1.5 + 2(4x4)	0.4	44(5.5)	476	583	485	100	DN150
WP4-150-4	30	1465	118.7	68.3	4x1.5 + 4x35	4x1.5 + 4x16	4x1.5 + 2(4x16)	4x1.5 + 2(4x6)	0.4	44(5.5)	502	609	510	100	DN150
WP4-150-4	37	1465	141.2	81.2	4x1.5 + 2(4x25)	4x1.5 + 4x16	4x1.5 + 2(4x25)	4x1.5 + 2(4x10)	0.4	44(5.5)	553	654	560	100	DN150
WP4-150-4	45	1465	171.7	98.8	4x1.5 + 2(4x25)	4x1.5 + 4x25	4x1.5 + 2(4x35)	4x1.5 + 2(4x10)	0.4	44(5.5)	596	697	603	100	DN150
WP4-150-4	55	1465	201.7	116.0	4x1.5 + 2(4x35)	4x1.5 + 4x35	4x1.5 + 2(4x35)	4x1.5 + 2(4x16)	0.4	44(5.5)	608	709	615	100	DN150
WP4-150-4	65	1475	238.3	137.0	NA	4x1.5 + 2(4x25)	4x1.5 + 2(4x35)	4x1.5 + 2(4x25)	0.4	44(5.5)	608	709	615	100	DN150
WP4-200-4	18.5	1465	71.4	41.0	4x1.5 + 4x16	4x1.5 + 4x6	4x1.5 + 2(4x10)	4x1.5 + 7x2.5	0.4	44(5.5)	515	615	547	100	DN200
WP4-200-4	22	1465	83.9	48.2	4x1.5 + 4x25	4x1.5 + 4x10	4x1.5 + 2(4x10)	4x1.5 + 2(4x4)	0.4	44(5.5)	525	625	557	100	DN200
WP4-200-4	30	1465	118.7	68.3	4x1.5 + 4x35	4x1.5 + 4x16	4x1.5 + 2(4x16)	4x1.5 + 2(4x6)	0.4	44(5.5)	533	638	570	100	DN200
WP4-200-4	37	1465	141.2	81.2	4x1.5 + 2(4x25)	4x1.5 + 4x16	4x1.5 + 2(4x25)	4x1.5 + 2(4x10)	0.4	44(5.5)	583	683	620	100	DN200
WP4-200-4	45	1465	171.7	98.8	4x1.5 + 2(4x25)	4x1.5 + 4x25	4x1.5 + 2(4x35)	4x1.5 + 2(4x10)	0.4	44(5.5)	626	726	663	100	DN200
WP4-200-4	55	1465	201.7	116.0	4x1.5 + 2(4x35)	4x1.5 + 4x35	4x1.5 + 2(4x35)	4x1.5 + 2(4x16)	0.4	44(5.5)	638	738	675	100	DN200
WP4-200-4	65	1475	238.3	137.0	NA	4x1.5 + 2(4x25)	4x1.5 + 2(4x35)	4x1.5 + 2(4x25)	0.4	44(5.5)	638	738	675	100	DN200
WP4-200-6	18.5	970	75.2	43.3	4x1.5 + 4x16	4x1.5 + 4x6	4x1.5 + 2(4x4)	4x1.5 + 7x2.5	0.4	44(5.5)	533	638	570	100	DN200
WP4-200-6	22	975	88.4	50.8	4x1.5 + 4x25	4x1.5 + 4x10	4x1.5 + 2(4x10)	4x1.5 + 2(4x4)	0.4	44(5.5)	566	666	603	100	DN200
WP4-200-6	30	975	120.0	69.0	4x1.5 + 4x35	4x1.5 + 4x16	4x1.5 + 2(4x10)	4x1.5 + 2(4x6)	0.4	44(5.5)	616	716	653	100	DN200
WP4-200-6	37	975	148.1	85.2	4x1.5 + 2(4x25)	4x1.5 + 4x25	4x1.5 + 2(4x10)	4x1.5 + 2(4x10)	0.4	44(5.5)	625	725	662	100	DN200
WP4-250-6	18.5	970	75.2	43.3	4x1.5 + 4x16	4x1.5 + 4x6	4x1.5 + 2(4x4)	4x1.5 + 7x2.5	0.4	44(5.5)	533	638	570	100	DN250
WP4-250-6	22	975	88.4	50.8	4x1.5 + 4x25	4x1.5 + 4x10	4x1.5 + 2(4x10)	4x1.5 + 2(4x4)	0.4	44(5.5)	566	666	603	100	DN250
WP4-250-6	30	975	120.0	69.0	4x1.5 + 4x35	4x1.5 + 4x16	4x1.5 + 2(4x10)	4x1.5 + 2(4x6)	0.4	44(5.5)	616	716	653	100	DN250
WP4-250-6	37	975	148.1	85.2	4x1.5 + 2(4x25)	4x1.5 + 4x25	4x1.5 + 2(4x10)	4x1.5 + 2(4x10)	0.4	44(5.5)	625	725	662	100	DN250
WP4-250-4	18.5	1465	71.4	41.0	4x1.5 + 4x16	4x1.5 + 4x6	4x1.5 + 2(4x10)	4x1.5 + 7x2.5	0.4	44(5.5)	533	638	570	100	DN250
WP4-250-4	22	1465	83.9	48.2	4x1.5 + 4x25	4x1.5 + 4x10	4x1.5 + 2(4x4)	4x1.5 + 2(4x4)	0.4	44(5.5)	513	618	550	100	DN250
WP4-250-4	30	1465	118.7	68.3	4x1.5 + 4x35	4x1.5 + 4x16	4x1.5 + 2(4x10)	4x1.5 + 2(4x6)	0.4	44(5.5)	533	638	570	100	DN250
WP4-250-4	37	1465	141.2	81.2	4x1.5 + 2(4x25)	4x1.5 + 4x16	4x1.5 + 2(4x10)	4x1.5 + 2(4x10)	0.4	44(5.5)	583	683	620	100	DN250
WP4-250-4	45	1465	171.7	98.8	4x1.5 + 2(4x25)	4x1.5 + 4x25	4x1.5 + 2(4x10)	4x1.5 + 2(4x10)	0.4	44(5.5)	626	726	663	100	DN250
WP4-250-4	55	1465	201.7	116.0	4x1.5 + 2(4x35)	4x1.5 + 4x35	4x1.5 + 2(4x35)	4x1.5 + 2(4x16)	0.4	44(5.5)	638	738	675	100	DN250
WP4-250-4	65	1475	238.3	137.0	NA	4x1.5 + 2(4x25)	4x1.5 + 2(4x35)	4x1.5 + 2(4x25)	0.4	44(5.5)	638	738	675	100	DN250
WP4-300-6	18.5	970	75.2	43.3	4x1.5 + 4x16	4x1.5 + 4x6	4x1.5 + 2(4x10)	4x1.5 + 7x2.5	0.4	44(5.5)	700	763	784	100	DN300
WP4-300-6	22	975	88.4	50.8	4x1.5 + 4x25	4x1.5 + 4x10	4x1.5 + 2(4x10)	4x1.5 + 2(4x4)	0.4	44(5.5)	733	791	817	100	DN300
WP4-300-6	30	975	120.0	69.0	4x1.5 + 4x35	4x1.5 + 4x16	4x1.5 + 2(4x6)	4x1.5 + 2(4x6)	0.4	44(5.5)	783	841	867	100	DN300
WP4-300-6	37	975	148.1	85.2	4x1.5 + 4x70	4x1.5 + 4x25	4x1.5 + 2(4x10)	4x1.5 + 2(4x10)	0.4	44(5.5)	792	850	876	100	DN300
WP4-300-6	45	975	180.1	103.6	4x1.5 + 2(4x35)	4x1.5 + 4x25	4x1.5 + 2(4x35)	4x1.5 + 2(4x16)	0.4	44(5.5)	1200	1210	1200	100	DN300
WP4-300-8	15	725	64.5	37.1	4x1.5 + 4x16	4x1.5 + 4x6	4x1.5 + 2(4x4)	4x1.5 + 7x2.5	0.4	44(5.5)	710	774	794	100	DN300
WP4-300-8	18.5	725	79.6	45.8	4x1.5 + 4x16	4x1.5 + 4x10	4x1.5 + 2(4x4)	4x1.5 + 7x2.5	0.4	44(5.5)	710	774	794	100	DN300
WP5-150-2	75	2955	222.6	128.0	4x1.5 + 2(4x50)	4x1.5 + 4x50	4x1.5 + 2(4x50)	4x1.5 + 2(4x16)	0.4	44(5.5)	1187	1505	1561	93	DN150
WP5-150-2	90	2955	264.3	152.0	4x1.5 + 2(4x50)	4x1.5 + 4x70	4x1.5 + 2(4x50)	4x1.5 + 2(4x25)	0.4	44(5.5)	1254	1572	1628	93	DN150
WP5-150-2	110	2955	318.3	183.0	4x1.5 + 2(4x70)	4x1.5 + 2(4x35)	4x1.5 + 2(4x70)	4x1.5 + 2(4x35)	0.4	44(5.5)	1282	1600	1656	93	DN150
WP5-150-2	132	2955	382.6	220.0	NA	4x1.5 + 2(4x35)	NA	4x1.5 + 2(4x35)	0.4	44(5.5)	1363	1681	1737	93	DN150
WP5-150-2	160	2955	460.9	265.0	NA	4x1.5 + 2(4x50)	NA	4x1.5 + 2(4x50)	0.4	44(5.5)	1345	1663	1719	93	DN150
WP5-150-2	200	2955	573.9	330.0	NA	4x1.5 + 2(4x70)	NA	4x1.5 + 2(4x70)	0.4	44(5.5)	1463	1781	1837	93	DN150
WP5-150-4	75	1475	231.3	133	4x1.5 + 2(4x50)	4x1.5 + 4x50	4x1.5 + 2(4x50)	4x1.5 + 2(4x16)	0.4	134(14)	1187	1505	1561	93	DN150
WP5-150-4	90	1475	273	157	4x1.5 + 2(4x50)	4x1.5 + 4x70	4x1.5 + 2(4x50)	4x1.5 + 2(4x25)	0.4	134(14)	1254	1572	1628	93	DN150
WP5-150-4	110	1475	332.2	191	4x1.5 + 2(4x70)	4x1.5 + 2(4x35)	4x1.5 + 2(4x70)	4x1.5 + 2(4x25)	0.4	118(14)	1282	1600	1656	93	DN150
WP5-150-4	132	1475	400	230	NA	4x1.5 + 2(4x35)	NA	4x1.5 + 2(4x25)	0.4	118(14)	1363	1681	1737	93	DN150
WP5-150-4	160	1475	478.3	275	NA	4x1.5 + 2(4x50)	NA	4x1.5 + 2(4x35)	0.4	118(14)	1345	1663	1719	93	DN150
WP5-150-4	200	1475	591.3	340	NA	4x1.5 + 2(4x70)	NA	4x1.5 + 2(4x70)	0.4	118(14)	1463	1781	1837	93	DN150
WP5-150-6	45	970	142.6	82	4x1.5 + 4x50	4x1.5 + 4x25	4x1.5 + 2(4x25)	4x1.5 + 2(4x10)	0.4	134(14)	1266	1584	1640	93	DN150
WP5-150-6	55	970	172.2	99	4x1.5 + 4x70	4x1.5 + 4x35	4x1.5 + 2(4x25)	4x1.5 + 2(4x10)	0.4	134(14)	1334	1652	1708	93	DN150

Type	kW P2	Rpm	I (A)		Cable DOL		Cable S/D		Oil	Coolant (w/o Cooling jacket)	Weight in kg Wet install	Weight in kg Dry install	Weight in kg Portable install	Throughlet in mm	Outlet flange
			230V	400V	3x230V	3x400V	3x230V	3x400V							
WPS-150-6	75	970	236.5	136	4x1.5-2(4x50)	4x1.5-4x50	4x1.5-2(4x50)	4x1.5-2(4x25)	0.4	134(14)	1428	1746	1802	93	DN150
WPS-150-6	90	970	280	161	4x1.5-2(4x70)	4x1.5-4x70	4x1.5-2(4x70)	4x1.5-2(4x25)	0.4	134(14)	1476	1794	1850	93	DN150
WPS-150-6	110	970	346.1	199	NA	4x1.5-2(4x35)	NA	4x1.5-2(4x35)	0.4	118(14)	1518	1836	1892	93	DN150
WPS-150-6	132	970	417.4	240	NA	4x1.5x-2(4x50)	NA	4x1.5-2(4x50)	0.4	118(14)	1476	1794	1850	93	DN150
WPS-150-6	160	970	504.3	290	NA	4x1.5-2(4x70)	NA	4x1.5-2(4x70)	0.4	118(14)	1518	1836	1892	93	DN150
WPS-150-8	37	750	130.4	75	4x1.5-4x50	4x1.5-4x25	4x1.5-2(4x16)	4x1.5-2(4x10)	0.4	134(14)	1201	1519	1575	93	DN150
WPS-150-8	45	750	153	88	4x1.5-4x70	4x1.5-4x25	4x1.5-2(4x25)	4x1.5-2(4x10)	0.4	134(14)	1249	1567	1623	93	DN150
WPS-150-8	55	750	184.3	106	4x1.5-2(4x35)	4x1.5-4x35	4x1.5-2(4x35)	4x1.5-2(4x16)	0.4	134(14)	1421	1739	1795	93	DN150
WPS-150-8	75	750	250.4	144	4x1.5x-2(4x50)	4x1.5-4x70	4x1.5x-2(4x50)	4x1.5-2(4x25)	0.4	134(14)	1499	1817	1873	93	DN150
WPS-150-8	90	750	292.2	168	4x1.5-2(4x70)	4x1.5-4x70	4x1.5-2(4x70)	4x1.5-2(4x25)	0.4	134(14)	1429	1567	1623	93	DN150
WPS-150-8	110	750	356.5	205	NA	4x1.5-2(4x35)	NA	4x1.5-2(4x35)	0.4	118(14)	1241	1739	1795	93	DN150
WPS-150-8	132	750	434.8	240	NA	4x1.5-4x70	NA	4x1.5-2(4x25)	0.4	118(14)	1499	1817	1873	93	DN150
WPS-200-2	75	2955	222.6	128	4x1.5-2(4x50)	4x1.5-4x50	4x1.5-2(4x50)	4x1.5-2(4x16)	0.4	134(14)	1276	1594	1650	130	DN200
WPS-200-2	90	2955	264.3	152	4x1.5x-2(4x50)	4x1.5x-4x50	4x1.5x-2(4x50)	4x1.5-2(4x25)	0.4	134(14)	1371	1689	1745	130	DN200
WPS-200-2	110	2955	318.3	183	4x1.5-2(4x70)	4x1.5-2(4x35)	4x1.5-2(4x70)	4x1.5-2(4x35)	0.4	118(14)	1371	1689	1745	130	DN200
WPS-200-2	132	2955	382.6	220	NA	4x1.5-2(4x35)	NA	4x1.5-2(4x35)	0.4	118(14)	1452	1770	1826	130	DN200
WPS-200-2	160	2955	460.9	265	NA	4x1.5-2(4x50)	NA	4x1.5-2(4x50)	0.4	118(14)	1434	1752	1808	130	DN200
WPS-200-2	200	2955	573.9	330	NA	4x1.5-2(4x70)	NA	4x1.5-2(4x70)	0.4	118(14)	1552	1870	1926	130	DN200
WPS-200-4	75	1475	231.3	133	4x1.5-2(4x50)	4x1.5-4x50	4x1.5-2(4x50)	4x1.5-2(4x16)	0.4	134(14)	1276	1594	1650	130	DN200
WPS-200-4	90	1475	273	157	4x1.5-2(4x50)	4x1.5-4x50	4x1.5-2(4x50)	4x1.5-2(4x25)	0.4	134(14)	1343	1661	1717	130	DN200
WPS-200-4	110	1475	332.2	191	4x1.5-2(4x70)	4x1.5-4x70	4x1.5-2(4x70)	4x1.5-2(4x25)	0.4	118(14)	1371	1689	1745	130	DN200
WPS-200-4	132	1475	400	230	NA	4x1.5-2(4x35)	NA	4x1.5-2(4x25)	0.4	118(14)	1452	1770	1826	130	DN200
WPS-200-4	160	1475	478.3	275	NA	4x1.5-2(4x50)	NA	4x1.5-2(4x35)	0.4	118(14)	1434	1752	1808	130	DN200
WPS-200-4	200	1475	591.3	340	NA	4x1.5-2(4x70)	NA	4x1.5-2(4x70)	0.4	118(14)	1552	1870	1926	130	DN200
WPS-200-6	45	970	142.6	82	4x1.5-4x70	4x1.5-4x25	4x1.5-2(4x25)	4x1.5-2(4x10)	0.4	134(14)	1355	1673	1729	130	DN200
WPS-200-6	55	970	172.2	99	4x1.5-4x70	4x1.5-4x35	4x1.5-2(4x25)	4x1.5-2(4x10)	0.4	134(14)	1423	1741	1797	130	DN200
WPS-200-6	75	970	236.5	136	4x1.5-2(4x70)	4x1.5-4x70	4x1.5-2(4x70)	4x1.5-2(4x25)	0.4	134(14)	1517	1835	1891	130	DN200
WPS-200-6	90	970	280	161	4x1.5-2(4x70)	4x1.5-4x70	4x1.5-2(4x70)	4x1.5-2(4x25)	0.4	134(14)	1355	1673	1729	130	DN200
WPS-200-6	110	970	346.1	199	NA	4x1.5-2(4x35)	NA	4x1.5-2(4x25)	0.4	118(14)	1565	1883	1939	130	DN200
WPS-200-6	132	970	417.4	240	NA	4x1.5-2(4x50)	NA	4x1.5-2(4x35)	0.4	118(14)	1607	1925	1981	130	DN200
WPS-200-6	160	970	504.3	290	NA	4x1.5-4x70	NA	4x1.5-2(4x25)	0.4	118(14)	1290	1608	1664	130	DN200
WPS-200-8	37	750	130.4	75	4x1.5-4x50	4x1.5-4x25	4x1.5-2(4x16)	4x1.5-2(4x10)	0.4	134(14)	1338	1656	1712	130	DN200
WPS-200-8	45	750	153	88	4x1.5-4x70	4x1.5-4x25	4x1.5-2(4x25)	4x1.5-2(4x10)	0.4	134(14)	1510	1828	1884	130	DN200
WPS-200-8	55	750	184.3	106	4x1.5-2(4x35)	4x1.5-4x35	4x1.5-2(4x35)	4x1.5-2(4x16)	0.4	134(14)	1588	1906	1962	130	DN200
WPS-200-8	75	750	250.4	144	4x1.5-2(4x50)	4x1.5-4x70	4x1.5-2(4x50)	4x1.5-2(4x25)	0.4	134(14)	1290	1608	1664	130	DN200
WPS-200-8	90	750	292.2	168	4x1.5-2(4x70)	4x1.5-4x70	4x1.5-2(4x70)	4x1.5-2(4x25)	0.4	134(14)	1338	1656	1712	130	DN200
WPS-200-8	110	750	356.5	205	NA	4x1.5-2(4x35)	NA	4x1.5-2(4x35)	0.4	118(14)	1510	1828	1884	130	DN200
WPS-200-8	132	750	434.8	250	NA	4x1.5-2(4x50)	NA	4x1.5-2(4x50)	0.4	118(14)	1588	1906	1962	130	DN200
WPS-250-2	75	2955	222.6	128	4x1.5-2(4x50)	4x1.5-4x50	4x1.5-2(4x50)	4x1.5-2(4x16)	0.4	134(14)	1295	1613	1669	130	DN250
WPS-250-2	90	2955	264.3	152	4x1.5-2(4x50)	4x1.5-4x70	4x1.5-2(4x50)	4x1.5-2(4x25)	0.4	134(14)	1362	1680	1736	130	DN250
WPS-250-2	110	2955	318.3	183	4x1.5x-2(4x70)	4x1.5-2(4x35)	4x1.5-2(4x70)	4x1.5-2(4x35)	0.4	118(14)	1390	1708	1764	130	DN250
WPS-250-2	132	2955	382.6	220	NA	4x1.5-2(4x35)	NA	4x1.5-2(4x35)	0.4	118(14)	1471	1789	1845	130	DN250
WPS-250-2	160	2955	460.9	265	NA	4x1.5-2(4x50)	NA	4x1.5-2(4x50)	0.4	118(14)	1453	1771	1827	130	DN250
WPS-250-2	200	2955	573.9	330	NA	4x1.5-4x70	NA	4x1.5-4x70	0.4	118(14)	1571	1889	1945	130	DN250
WPS-250-4	75	1475	231.3	133	4x1.5-2(4x50)	4x1.5-4x50	4x1.5-2(4x50)	4x1.5-2(4x16)	0.4	134(14)	1295	1613	1669	130	DN250
WPS-250-4	90	1475	273	157	4x1.5-2(4x50)	4x1.5-4x50	4x1.5-2(4x50)	4x1.5-2(4x16)	0.4	134(14)	1362	1680	1736	130	DN250
WPS-250-4	110	1475	332.2	191	4x1.5-2(4x70)	4x1.5-4x70	4x1.5-2(4x70)	4x1.5-2(4x25)	0.4	118(14)	1390	1708	1764	130	DN250
WPS-250-4	132	1475	400	230	NA	4x1.5-2(4x35)	NA	4x1.5-2(4x25)	0.4	118(14)	1471	1789	1845	130	DN250
WPS-250-4	160	1475	478.3	275	NA	4x1.5-2(4x50)	NA	4x1.5-2(4x35)	0.4	118(14)	1453	1771	1827	130	DN250
WPS-250-4	200	1475	591.3	340	NA	4x1.5-2(4x70)	NA	4x1.5-2(4x70)	0.4	118(14)	1571	1889	1945	130	DN250
WPS-250-6	45	970	142.6	82	4x1.5-4x50	4x1.5-4x25	4x1.5-2(4x25)	4x1.5-2(4x10)	0.4	134(14)	1374	1692	1748	130	DN250
WPS-250-6	55	970	172.2	99	4x1.5-4x70	4x1.5-4x35	4x1.5-2(4x25)	4x1.5-2(4x10)	0.4	134(14)	1442	1760	1816	130	DN250
WPS-250-6	75	970	236.5	136	4x1.5-2(4x50)	4x1.5-4x50	4x1.5-2(4x50)	4x1.5-2(4x25)	0.4	134(14)	1536	1854	1910	130	DN250
WPS-250-6	90	970	280	161	4x1.5-2(4x70)	4x1.5-4x70	4x1.5-2(4x70)	4x1.5-2(4x25)	0.4	134(14)	1584	1902	1958	130	DN250
WPS-250-6	110	970	346.1	199	NA	4x1.5-2(4x35)	NA	4x1.5-2(4x35)	0.4	118(14)	1626	1944	2000	130	DN250
WPS-250-6	132	970	417.4	240	NA	4x1.5-2(4x50)	NA	4x1.5-2(4x50)	0.4	118(14)	1584	1902	1958	130	DN250
WPS-250-6	160	970	504.3	290	NA	4x1.5-2(4x70)	NA	4x1.5-2(4x70)	0.4	118(14)	1626	1944	2000	130	DN250
WPS-250-8	37	750	130.4	75	4x1.5-4x50	4x1.5-4x25	4x1.5-2(4x10)	4x1.5-2(4x10)	0.4	134(14)	1309	1627	1683	130	DN250

Type	kW P2	Rpm	I (A)		Cable DOL		Cable S/D		Oil	Coolant (w/o Cooling jacket)	Weight in kg Wet install	Weight in kg Dry install	Weight in kg Portable install	Throughlet in mm	Outlet flange
			230V	400V	3x230V	3x400V	3x230V	3x400V							
WPS-250-8	45	750	153	88	4x1.5 - 4x70	4x1.5 - 4x25	4x1.5 - 2(4x10)	4x1.5 - 2(4x10)	0.4	134(14)	1357	1675	1731	130	DN250
WPS-250-8	55	750	184.3	106	4x1.5 - 2(4x35)	4x1.5 - 4x35	4x1.5 - 2(4x16)	4x1.5 - 2(4x16)	0.4	134(14)	1529	1847	1903	130	DN250
WPS-250-8	75	750	250.4	144	4x1.5 - 2(4x50)	4x1.5 - 4x70	4x1.5 - 2(4x25)	4x1.5 - 2(4x25)	0.4	134(14)	1607	1925	1981	130	DN250
WPS-250-8	90	750	292.2	168	4x1.5 - 2(4x70)	4x1.5 - 2(4x25)	4x1.5 - 2(4x70)	4x1.5 - 2(4x25)	0.4	134(14)	1357	1675	1731	130	DN250
WPS-250-8	110	750	356.5	205	NA	4x1.5 - 2(4x35)	NA	4x1.5 - 2(4x35)	0.4	118(14)	1529	1847	1903	130	DN250
WPS-250-8	132	750	434.8	250	NA	4x1.5 - 2(4x50)	NA	4x1.5 - 2(4x50)	0.4	118(14)	1607	1925	1981	130	DN250
WPS-300-2	75	2955	222.6	128	4x1.5 - 2(4x50)	4x1.5 - 4x50	4x1.5 - 2(4x50)	4x1.5 - 2(4x16)	0.4	134(14)	1329	1647	1703	130	DN300
WPS-300-2	90	2955	264.3	152	4x1.5 - 2(4x50)	4x1.5 - 4x70	4x1.5 - 2(4x50)	4x1.5 - 2(4x25)	0.4	134(14)	1396	1714	1770	130	DN300
WPS-300-2	110	2955	318.3	183	4x1.5 - 2(4x70)	4x1.5 - 2(4x35)	4x1.5 - 2(4x70)	4x1.5 - 2(4x35)	0.4	118(14)	1424	1742	1798	130	DN300
WPS-300-2	132	2955	382.6	220	NA	4x1.5 - 2(4x25)	NA	4x1.5 - 2(4x25)	0.4	118(14)	1505	1823	1879	130	DN300
WPS-300-2	160	2955	460.9	265	NA	4x1.5 - 2(4x50)	NA	4x1.5 - 2(4x50)	0.4	118(14)	1487	1805	1861	130	DN300
WPS-300-2	200	2955	573.9	330	NA	4x1.5 - 2(4x70)	NA	4x1.5 - 2(4x70)	0.4	118(14)	1605	1923	1979	130	DN300
WPS-300-4	75	1475	231.3	133	4x1.5 - 2(4x50)	4x1.5 - 4x50	4x1.5 - 2(4x50)	4x1.5 - 2(4x16)	0.4	134(14)	1329	1647	1703	130	DN300
WPS-300-4	90	1475	273	157	4x1.5 - 2(4x50)	4x1.5 - 4x70	4x1.5 - 2(4x50)	4x1.5 - 2(4x16)	0.4	134(14)	1396	1714	1770	130	DN300
WPS-300-4	110	1475	332.2	191	4x1.5 - 2(4x70)	4x1.5 - 2(4x35)	4x1.5 - 2(4x70)	4x1.5 - 2(4x35)	0.4	118(14)	1424	1742	1798	130	DN300
WPS-300-4	132	1475	400	230	NA	4x1.5 - 2(4x35)	NA	4x1.5 - 2(4x25)	0.4	118(14)	1505	1823	1879	130	DN300
WPS-300-4	160	1475	478.3	275	NA	4x1.5 - 2(4x50)	NA	4x1.5 - 2(4x35)	0.4	118(14)	1487	1805	1861	130	DN300
WPS-300-4	200	1475	591.3	340	NA	4x1.5 - 2(4x70)	NA	4x1.5 - 2(4x70)	0.4	118(14)	1605	1923	1979	130	DN300
WPS-300-6	45	970	142.6	82	4x1.5 - 4x70	4x1.5 - 4x25	4x1.5 - 2(4x25)	4x1.5 - 2(4x16)	0.4	134(14)	1408	1726	1782	130	DN300
WPS-300-6	55	970	172.2	99	4x1.5 - 4x70	4x1.5 - 4x35	4x1.5 - 2(4x25)	4x1.5 - 2(4x16)	0.4	134(14)	1476	1794	1850	130	DN300
WPS-300-6	75	970	236.5	136	4x1.5 - 2(4x50)	4x1.5 - 4x70	4x1.5 - 2(4x50)	4x1.5 - 2(4x25)	0.4	134(14)	1570	1888	1944	130	DN300
WPS-300-6	90	970	280	161	4x1.5 - 2(4x70)	4x1.5 - 4x70	4x1.5 - 2(4x70)	4x1.5 - 2(4x25)	0.4	134(14)	1618	1936	1992	130	DN300
WPS-300-6	110	970	346.1	199	NA	4x1.5 - 2(4x50)	NA	4x1.5 - 2(4x35)	0.4	118(14)	1660	1978	2034	130	DN300
WPS-300-6	132	970	417.4	240	NA	4x1.5 - 2(4x50)	NA	4x1.5 - 2(4x50)	0.4	118(14)	1618	1936	1992	130	DN300
WPS-300-6	160	970	504.3	290	NA	4x1.5 - 2(4x70)	NA	4x1.5 - 2(4x70)	0.4	118(14)	1660	1978	2034	130	DN300
WPS-300-8	37	750	130.4	75	4x1.5 - 4x50	4x1.5 - 4x25	4x1.5 - 2(4x16)	4x1.5 - 2(4x10)	0.4	134(14)	1343	1661	1717	130	DN300
WPS-300-8	45	750	153	88	4x1.5 - 4x70	4x1.5 - 4x25	4x1.5 - 2(4x25)	4x1.5 - 2(4x10)	0.4	134(14)	1391	1709	1765	130	DN300
WPS-300-8	55	750	184.3	106	4x1.5 - 2(4x35)	4x1.5 - 4x35	4x1.5 - 2(4x35)	4x1.5 - 2(4x16)	0.4	134(14)	1563	1881	1937	130	DN300
WPS-300-8	75	750	250.4	144	4x1.5 - 2(4x50)	4x1.5 - 4x70	4x1.5 - 2(4x50)	4x1.5 - 2(4x25)	0.4	134(14)	1641	1959	2015	130	DN300
WPS-300-8	90	750	292.2	168	4x1.5 - 2(4x70)	4x1.5 - 4x70	4x1.5 - 2(4x70)	4x1.5 - 2(4x25)	0.4	134(14)	1591	1709	1765	130	DN300
WPS-300-8	110	750	356.5	205	NA	4x1.5 - 2(4x35)	NA	4x1.5 - 2(4x35)	0.4	118(14)	1563	1881	1937	130	DN300
WPS-300-8	132	750	434.8	250	NA	4x1.5 - 2(4x50)	NA	4x1.5 - 2(4x50)	0.4	118(14)	1641	1959	2015	130	DN300
WPS-350-2	75	2955	222.6	128	4x1.5 - 2(4x50)	4x1.5 - 4x50	4x1.5 - 2(4x50)	4x1.5 - 2(4x16)	0.4	134(14)	1424	1742	1798	130	DN350
WPS-350-2	90	2955	264.3	152	4x1.5 - 2(4x50)	4x1.5 - 4x70	4x1.5 - 2(4x50)	4x1.5 - 2(4x25)	0.4	134(14)	1491	1809	1865	130	DN350
WPS-350-2	110	2955	318.3	183	4x1.5 - 2(4x70)	4x1.5 - 2(4x35)	4x1.5 - 2(4x70)	4x1.5 - 2(4x35)	0.4	118(14)	1519	1837	1893	130	DN350
WPS-350-2	132	2955	382.6	220	NA	4x1.5 - 2(4x35)	NA	4x1.5 - 2(4x35)	0.4	118(14)	1600	1918	1974	130	DN350
WPS-350-2	160	2955	460.9	265	NA	4x1.5 - 2(4x50)	NA	4x1.5 - 2(4x50)	0.4	118(14)	1582	1900	1956	130	DN350
WPS-350-2	200	2955	573.9	330	NA	4x1.5 - 2(4x70)	NA	4x1.5 - 2(4x70)	0.4	118(14)	1700	2018	2074	130	DN350
WPS-350-4	75	1475	231.3	133	4x1.5 - 2(4x50)	4x1.5 - 4x50	4x1.5 - 2(4x50)	4x1.5 - 2(4x16)	0.4	134(14)	1424	1742	1798	130	DN350
WPS-350-4	90	1475	273	157	4x1.5 - 2(4x50)	4x1.5 - 4x50	4x1.5 - 2(4x50)	4x1.5 - 2(4x16)	0.4	134(14)	1491	1809	1865	130	DN350
WPS-350-4	110	1475	332.2	191	4x1.5 - 2(4x70)	4x1.5 - 2(4x35)	4x1.5 - 2(4x70)	4x1.5 - 2(4x35)	0.4	118(14)	1519	1837	1893	130	DN350
WPS-350-4	132	1475	400	230	NA	4x1.5 - 2(4x35)	NA	4x1.5 - 2(4x50)	0.4	118(14)	1600	1918	1974	130	DN350
WPS-350-4	160	1475	478.3	275	NA	4x1.5 - 2(4x50)	NA	4x1.5 - 2(4x35)	0.4	118(14)	1582	1900	1956	130	DN350
WPS-350-4	200	1475	591.3	340	NA	4x1.5 - 2(4x70)	NA	4x1.5 - 2(4x70)	0.4	118(14)	1700	2018	2074	130	DN350
WPS-350-6	45	970	142.6	82	4x1.5 - 2(4x50)	4x1.5 - 4x25	4x1.5 - 2(4x50)	4x1.5 - 2(4x10)	0.4	134(14)	1503	1821	1877	130	DN350
WPS-350-6	55	970	172.2	99	4x1.5 - 4x70	4x1.5 - 4x35	4x1.5 - 2(4x25)	4x1.5 - 2(4x10)	0.4	134(14)	1571	1889	1945	130	DN350
WPS-350-6	75	970	236.5	136	4x1.5 - 2(4x50)	4x1.5 - 4x50	4x1.5 - 2(4x50)	4x1.5 - 2(4x25)	0.4	134(14)	1665	1983	2039	130	DN350
WPS-350-6	90	970	280	161	4x1.5 - 2(4x70)	4x1.5 - 4x70	4x1.5 - 2(4x70)	4x1.5 - 2(4x25)	0.4	134(14)	1713	2031	2087	130	DN350
WPS-350-6	110	970	346.1	199	NA	4x1.5 - 2(4x35)	NA	4x1.5 - 2(4x35)	0.4	118(14)	1665	1983	2039	130	DN350
WPS-350-6	132	970	417.4	240	NA	4x1.5 - 2(4x50)	NA	4x1.5 - 2(4x50)	0.4	118(14)	1713	2031	2087	130	DN350
WPS-350-6	160	970	504.3	290	NA	4x1.5 - 2(4x50)	NA	4x1.5 - 2(4x50)	0.4	118(14)	1755	2073	2129	130	DN350
WPS-350-8	37	750	130.4	75	4x1.5 - 4x50	4x1.5 - 4x25	4x1.5 - 2(4x16)	4x1.5 - 2(4x10)	0.4	134(14)	1438	1756	1812	130	DN350
WPS-350-8	45	750	153	88	4x1.5 - 4x70	4x1.5 - 4x25	4x1.5 - 2(4x35)	4x1.5 - 2(4x10)	0.4	134(14)	1486	1804	1860	130	DN350
WPS-350-8	55	750	184.3	106	4x1.5 - 2(4x35)	4x1.5 - 4x35	4x1.5 - 2(4x35)	4x1.5 - 2(4x16)	0.4	134(14)	1658	1976	2032	130	DN350
WPS-350-8	75	750	250.4	144	4x1.5 - 2(4x50)	4x1.5 - 4x70	4x1.5 - 2(4x50)	4x1.5 - 2(4x35)	0.4	134(14)	1736	2054	2110	130	DN350
WPS-350-8	90	750	292.2	168	4x1.5 - 2(4x70)	4x1.5 - 4x70	4x1.5 - 2(4x70)	4x1.5 - 2(4x25)	0.4	134(14)	1486	1804	1860	130	DN350
WPS-350-8	110	750	356.5	205	NA	4x1.5 - 2(4x35)	NA	4x1.5 - 2(4x35)	0.4	118(14)	1658	1976	2032	130	DN350
WPS-350-8	132	750	434.8	250	NA	4x1.5 - 2(4x50)	NA	4x1.5 - 2(4x50)	0.4	118(14)	1736	2054	2110	130	DN350

Type	kW P2	Rpm	I (A)		Cable DOL		Cable S/D		Oil	Coolant (w/o Cooling jacket)	Weight in kg Wet install	Weight in kg Dry install	Weight in kg Portable install	Throughlet in mm	Outlet flange
			230V	400V	3x230V	3x400V	3x230V	3x400V							
WPS-400-2	75	2955	222.6	128	4x1.5 + 2(4x50)	4x1.5 + 4x50	4x1.5 + 2(4x50)	4x1.5 - 2(4x16)	0.4	134(14)	1684	2002	2058	145	DN400
WPS-400-2	90	2955	264.3	152	4x1.5 + 2(4x50)	4x1.5 + 4x70	4x1.5 + 2(4x50)	4x1.5 - 2(4x25)	0.4	134(14)	1751	2069	2125	145	DN400
WPS-400-2	110	2955	318.3	183	4x1.5 + 2(4x70)	4x1.5 + 2(4x35)	4x1.5 + 2(4x70)	4x1.5 - 2(4x35)	0.4	118(14)	1779	2097	2153	145	DN400
WPS-400-2	132	2955	382.6	220	NA	4x1.5 + 2(4x35)	NA	4x1.5 - 2(4x35)	0.4	118(14)	1860	2178	2234	145	DN400
WPS-400-2	160	2955	460.6	265	NA	4x1.5 + 2(4x50)	NA	4x1.5 - 2(4x50)	0.4	118(14)	1842	2160	2216	145	DN400
WPS-400-2	200	2955	573.9	330	NA	4x1.5 + 2(4x70)	NA	4x1.5 - 2(4x70)	0.4	118(14)	1960	2278	2334	145	DN400
WPS-400-4	75	1475	231.3	133	4x1.5 + 2(4x50)	4x1.5 + 4x70	4x1.5 + 2(4x50)	4x1.5 - 2(4x16)	0.4	134(14)	1684	2002	2058	145	DN400
WPS-400-4	90	1475	273	157	4x1.5 + 2(4x50)	4x1.5 + 4x50	4x1.5 + 2(4x50)	4x1.5 - 2(4x16)	0.4	134(14)	1751	2069	2125	145	DN400
WPS-400-4	110	1475	332.2	191	4x1.5 + 2(4x70)	4x1.5 + 4x70	4x1.5 + 2(4x70)	4x1.5 - 2(4x25)	0.4	118(14)	1779	2097	2153	145	DN400
WPS-400-4	132	1475	400	230	NA	4x1.5 + 2(4x35)	NA	4x1.5 - 2(4x25)	0.4	118(14)	1860	2178	2234	145	DN400
WPS-400-4	160	1475	478.3	275	NA	4x1.5 + 2(4x50)	NA	4x1.5 - 2(4x35)	0.4	118(14)	1842	2160	2216	145	DN400
WPS-400-4	200	1475	591.3	340	NA	4x1.5 + 2(4x70)	NA	4x1.5 - 2(4x70)	0.4	118(14)	1960	2278	2334	145	DN400
WPS-400-6	45	970	142.2	82	4x1.5 + 4x70	4x1.5 + 4x25	4x1.5 + 2(4x50)	4x1.5 - 2(4x10)	0.4	134(14)	1763	2081	2137	145	DN400
WPS-400-6	55	970	172.2	99	4x1.5 + 4x70	4x1.5 + 4x35	4x1.5 + 2(4x25)	4x1.5 - 2(4x10)	0.4	134(14)	1831	2149	2205	145	DN400
WPS-400-6	75	970	236.5	136	4x1.5 + 2(4x50)	4x1.5 + 4x50	4x1.5 + 2(4x50)	4x1.5 - 2(4x25)	0.4	134(14)	1925	2243	2299	145	DN400
WPS-400-6	90	970	280	161	4x1.5 + 2(4x70)	4x1.5 + 4x70	4x1.5 + 2(4x70)	4x1.5 - 2(4x25)	0.4	134(14)	1973	2291	2347	145	DN400
WPS-400-6	110	970	346.1	199	NA	4x1.5 + 2(4x35)	NA	4x1.5 - 2(4x35)	0.4	118(14)	2015	2333	2389	145	DN400
WPS-400-6	132	970	417.4	240	NA	4x1.5 + 2(4x50)	NA	4x1.5 - 2(4x50)	0.4	118(14)	1973	2291	2347	145	DN400
WPS-400-6	160	970	504.3	290	NA	4x1.5 + 2(4x50)	NA	4x1.5 - 2(4x50)	0.4	118(14)	2015	2333	2389	145	DN400
WPS-400-8	37	750	130.4	75	4x1.5 + 4x50	4x1.5 + 4x25	4x1.5 + 2(4x16)	4x1.5 - 2(4x10)	0.4	134(14)	1698	2016	2072	145	DN400
WPS-400-8	45	750	153	88	4x1.5 + 4x70	4x1.5 + 4x25	4x1.5 + 2(4x25)	4x1.5 - 2(4x10)	0.4	134(14)	1746	2064	2120	145	DN400
WPS-400-8	55	750	184.3	106	4x1.5 + 2(4x35)	4x1.5 + 4x35	4x1.5 + 2(4x35)	4x1.5 - 2(4x16)	0.4	134(14)	1918	2236	2292	145	DN400
WPS-400-8	75	750	250.4	144	4x1.5 + 2(4x50)	4x1.5 + 4x70	4x1.5 + 2(4x50)	4x1.5 - 2(4x25)	0.4	134(14)	1996	2314	2370	145	DN400
WPS-400-8	90	750	292.2	168	4x1.5 + 2(4x70)	4x1.5 + 4x70	4x1.5 + 2(4x70)	4x1.5 - 2(4x25)	0.4	134(14)	1746	2064	2120	145	DN400
WPS-400-8	110	750	356.5	205	NA	4x1.5 + 2(4x35)	NA	4x1.5 - 2(4x35)	0.4	118(14)	1918	2236	2292	145	DN400
WPS-400-8	132	750	434.6	250	NA	4x1.5 + 2(4x50)	NA	4x1.5 - 2(4x50)	0.4	118(14)	1996	2314	2370	145	DN400

*Coolant = 80% water & 20% propylene glycol

Pump Data – 60 Hz

Type	kW P2	Rpm	I (A)				Cable DOL		Cable S/D		Oil	Coolant (w/o Cooling jacket)	Weight in kg Wet install	Weight in kg Dry install	Weight in kg Portable install	Throughlet in mm	Outlet flange
			start I (A)	230V	460V	575V	3x230V	3x400V	3x230V	3x400V							
WP0-37-2	0.75	2850	3.5	3.5	1.4	NA	3x1.5	4x1.5	NA	NA	0.6	NA	14	NA	14	36	R1½"
WP0-50-2	1	2850	4.2	5.8	NA	NA	3x1.5	NA	NA	NA	0.3	NA	22	NA	22	45	R2"
WP0-50-2	1	2850	4.2	5.8	2.2	NA	3x1.5	4x1.5	NA	NA	0.3	NA	22	NA	22	45	R2"
WP1-65-4	1.1	1430	4.5	5.9	3.0	NA	4x1.5 / 7x1.5	4x1.5 / 7x1.5	NA	NA	0.4	NA	32	NA	33	55	R2½"
WP1-65-2	1.85	2850	3.8	7.0	4.0	NA	4x1.5 / 7x1.5	4x1.5 / 7x1.5	NA	NA	0.4	NA	33	NA	34	55	R2½"
WP1-65-2	2.2	2850	4.1	9.4	5.5	NA	4x1.5 / 7x1.5	4x1.5 / 7x1.5	NA	NA	0.4	NA	40	NA	41	55	R2½"
WP1-70-2	1.8	3490	7.6	3.6	3	7x1.5	7x1.5	12x1.5	12x1.5	0.32	2.9(0.5)	88	103.3	108.3	60	DN80	
WP1-70-2	2.7	3490	10.0	5.0	4	7x1.5	7x1.5	12x1.5	12x1.5	0.32	2.9(0.5)	90	105.3	110.3	60	DN80	
WP1-70-2	3.5	3490	12.4	6.1	4.9	7x1.5	7x1.5	12x1.5	12x1.5	0.32	2.9(0.5)	92	107.3	112.3	60	DN80	
WP1-70-2	4.4	3490	6.8	13.5	6.7	5.4	7x1.5	7x1.5	12x1.5	12x1.5	0.32	2.9(0.5)	95	110.3	115.3	60	DN80
WP1-80-4	1.3	1720	5.8	2.9	2.3	7x1.5	7x1.5	12x1.5	12x1.5	0.32	2.9(0.5)	87	102.3	107.3	70	DN100	
WP1-80-4	1.8	1720	7.6	3.8	3	7x1.5	7x1.5	12x1.5	12x1.5	0.32	2.9(0.5)	89	104.3	109.3	70	DN100	
WP1-80-4	2.3	1720	10.0	4.2	4	7x1.5	7x1.5	12x1.5	12x1.5	0.32	2.9(0.5)	91	106.3	111.3	70	DN100	
WP1-80-4	2.7	1720	10.0	4.8	4	7x1.5	7x1.5	12x1.5	12x1.5	0.32	2.9(0.5)	93	108.3	113.3	70	DN100	
WP1-80-4	3.5	1720	5.6	13.0	6.4	5.2	7x1.5	7x1.5	12x1.5	12x1.5	0.32	2.9(0.5)	95	110.3	115.3	70	DN100
WP2-80-2	7.3	3499	28.6	14.3	11.4	7x2.5	7x2.5	7x2.5	7x2.5	0.45	5.7(1.3)	143	171.3	176.3	70	DN80	
WP2-80-2	11	3499	8.6	46.4	23.2	18.5	NA	7x2.5	7x2.5	12x1.5	0.45	5.7(1.3)	148	176.3	181.3	70	DN80
WP2-80-2	12.6	3499	0.0	46.4	23.2	18.5	NA	7x2.5	7x2.5	12x1.5	0.45	5.7(1.3)	151	179.3	184.3	70	DN80

Type	kW P2	Rpm	I (A)			Cable DOL			Cable S/D		Oil	Coolant (w/o Cooling jacket)	Weight in kg Wet install	Weight in kg Dry install	Weight in kg Portable install	Throughlet in mm	Outlet flange
			start I (A)	I (A)		3x230V	3x400V	3x230V	3x400V								
				230V	460V					575V							
WP2-100-6	3.3	1140	10.4	5.1	4.1	7x1.5	7x1.5	7x1.5	12x1.5	0.45	5.7(1.3)	142	170.3	175.3	100	DN100	
WP2-100-6	6.3	1140	0.0	25.3	12.6	10.1	7x2.5	7x1.5	7x2.5	12x1.5	0.45	5.7(1.3)	150	178.3	183.3	100	DN100
WP2-100-4	5.6	1740	0.6	17.2	8.6	6.9	7x2.5	7x1.5	12x1.5	12x1.5	0.45	5.7(1.3)	143	171.3	176.3	100	DN100
WP2-100-4	7.3	1740	6.0	30.8	15.4	9	NA	7x1.5	NA	12x1.5	0.45	5.7(1.3)	151	179.3	184.3	100	DN100
WP2-100-4	8.6	1740	0.0	31.2	15.6	12.5	NA	7x2.5	7x2.5	12x1.5	0.45	5.7(1.3)	156	184.3	189.3	100	DN100
WP2-100-4	11	1740	46.4	23.2	18.5	NA	7x2.5	7x2.5	7x2.5	12x1.5	0.45	5.7(1.3)	160	188.3	193.3	100	DN100
WP2-150-6	3.3	1140	4.6	15.6	7.8	NA	7x1.5	7x1.5	12x1.5	12x1.5	0.45	5.7(1.3)	156	184.3	189.3	100	DN150
WP2-150-6	6.3	1140	25.3	12.6	10.1	7x2.5	7x1.5	7x2.5	12x1.5	12x1.5	0.45	5.7(1.3)	160	188.3	193.3	100	DN150
WP2-150-4	5.6	1740	6.0	17.2	8.6	6.9	NA	7x1.5	12x1.5	12x1.5	0.45	5.7(1.3)	148	176.3	181.3	100	DN150
WP2-150-4	7.3	1740	6.0	30.8	15.4	9	NA	7x1.5	NA	12x1.5	0.45	5.7(1.3)	159	187.3	192.3	100	DN150
WP2-150-4	8.6	1740	0.0	31.2	15.6	12.5	NA	7x2.5	7x2.5	12x1.5	0.45	5.7(1.3)	167	195.3	200.3	100	DN150
WP2-150-4	11	1740	46.4	23.2	18.5	NA	7x2.5	7x2.5	7x2.5	12x1.5	0.45	5.7(1.3)	171	199.3	204.3	100	DN150
WP3-80-2	8.6	3540	28.6	14.3	11.4	4x1.5 + 4x4	7x2.5	4x1.5 + 7x2.5	12x1.5	0.15	11(3.5)	197	234	239	70	DN100	
WP3-80-2	11	3540	42.9	21.4	17.1	4x1.5 + 4x6	7x2.5	4x1.5 + 7x2.5	12x1.5	0.15	11(3.5)	210	247	252	70	DN100	
WP3-80-2	14	3540	59.7	29.9	23.8	4x1.5 + 4x10	4x1.5 + 4x6	4x1.5 + 4x10	4x1.5 + 2(4x4)	0.15	11(3.5)	217	254	259	70	DN100	
WP3-80-2	21.3	3540	78.4	39.1	31.3	4x1.5 + 2(4x10)	4x1.5 + 4x10	4x1.5 + 2(4x10)	4x1.5 + 2(4x4)	0.15	11(3.5)	252	289	294	70	DN100	
WP3-80-2	25.3	3540	82.8	41.3	33.1	4x1.5 + 2(4x10)	4x1.5 + 4x10	4x1.5 + 2(4x10)	4x1.5 + 2(4x4)	0.15	11(3.5)	255	292	297	70	DN100	
WP3-80-2	28	3540	113.5	56.9	45.5	4x1.5 + 2(4x16)	4x1.5 + 4x16	4x1.5 + 2(4x16)	4x1.5 + 2(4x4)	0.15	11(3.5)	261	298	303	70	DN100	
WP3-100-4	8.6	1740	31.2	15.6	12.5	4x1.5 + 4x4	7x2.5	4x1.5 + 7x2.5	12x1.5	0.15	11(3.5)	201	238	243	100	DN100	
WP3-100-4	11	1740	46.4	23.2	18.5	4x1.5 + 4x6	7x2.5	4x1.5 + 7x2.5	12x1.5	0.15	11(3.5)	204	241	246	100	DN100	
WP3-100-4	14	1740	63.2	31.6	25.3	4x1.5 + 4x6	4x1.5 + 4x6	4x1.5 + 4x10	4x1.5 + 2(4x4)	0.15	11(3.5)	225	262	267	100	DN100	
WP3-100-4	21.3	1740	78.4	39.1	31.3	4x1.5 + 2(4x10)	4x1.5 + 4x10	4x1.5 + 2(4x10)	4x1.5 + 2(4x4)	0.15	11(3.5)	241	278	283	100	DN100	
WP3-100-4	25.3	1740	81.0	41.0	31.0	4x1.5 + 2(4x10)	4x1.5 + 4x10	4x1.5 + 2(4x10)	4x1.5 + 2(4x4)	0.15	11(3.5)	245	282	287	100	DN100	
WP3-100-4	28	1740	0.0	113.5	56.9	45.5	4x1.5 + 2(4x16)	4x1.5 + 4x16	4x1.5 + 2(4x4)	0.15	11(3.5)	251	288	293	100	DN100	
WP3-100-6	7.5	1140	25.3	12.6	10.1	4x1.5 + 4x4	7x2.5	4x1.5 + 7x2.5	12x1.5	0.15	11(3.5)	201	238	243	100	DN100	
WP3-100-6	12.6	1140	50.0	24.9	20	4x1.5 + 4x6	7x2.5	4x1.5 + 7x2.5	12x1.5	0.15	11(3.5)	207	244	249	100	DN100	
WP3-150-4	8.6	1740	31.2	15.6	12.5	4x1.5 + 4x4	7x2.5	4x1.5 + 7x2.5	12x1.5	0.15	11(3.5)	208	245	250	100	DN150	
WP3-150-4	11	1740	46.4	23.2	18.5	4x1.5 + 4x6	7x2.5	4x1.5 + 7x2.5	12x1.5	0.15	11(3.5)	217	254	259	100	DN150	
WP3-150-4	14	1740	63.2	31.6	25.3	4x1.5 + 4x10	4x1.5 + 4x6	4x1.5 + 4x10	4x1.5 + 2(4x4)	0.15	11(3.5)	238	275	280	100	DN150	
WP3-150-4	21.3	1740	78.4	39.1	31.3	4x1.5 + 2(4x10)	4x1.5 + 4x10	4x1.5 + 2(4x10)	4x1.5 + 2(4x4)	0.15	11(3.5)	255	292	297	100	DN150	
WP3-150-4	25.3	1740	81.0	41.0	31.0	4x1.5 + 2(4x10)	4x1.5 + 4x10	4x1.5 + 2(4x10)	4x1.5 + 2(4x4)	0.15	11(3.5)	260	297	302	100	DN150	
WP3-150-4	28	1740	0.0	113.5	56.9	45.5	4x1.5 + 2(4x16)	4x1.5 + 4x16	4x1.5 + 2(4x4)	0.15	11(3.5)	266	303	308	100	DN150	
WP3-150-6	7.5	1140	25.3	12.6	10.1	4x1.5 + 4x4	7x2.5	4x1.5 + 7x2.5	12x1.5	0.15	11(3.5)	217	254	259	100	DN150	
WP3-150-6	12.6	1140	50.0	24.9	20	4x1.5 + 4x6	7x2.5	4x1.5 + 7x2.5	12x1.5	0.15	11(3.5)	227	264	269	100	DN150	
WP4-100-4	21.3	1740	90.5	45.2	36.1	4x1.5 + 4x25	4x1.5 + 4x10	4x1.5 + 2(4x35)	4x1.5 + 2(4x4)	0.4	44(5.5)	441	551	561	80	DN100	
WP4-100-4	25.3	1740	90.5	45.2	36.1	4x1.5 + 4x25	4x1.5 + 4x10	4x1.5 + 2(4x35)	4x1.5 + 2(4x4)	0.4	44(5.5)	453	563	573	80	DN100	
WP4-100-4	33.5	1740	121.1	60.6	48.5	4x1.5 + 4x35	4x1.5 + 4x16	4x1.5 + 2(4x35)	4x1.5 + 2(4x6)	0.4	44(5.5)	499	609	619	80	DN100	
WP4-100-4	42.5	1740	145.3	72.7	58	4x1.5 + 4x50	4x1.5 + 4x25	4x1.5 + 2(4x35)	4x1.5 + 2(4x10)	0.4	44(5.5)	549	659	669	80	DN100	
WP4-100-4	52	1740	177.2	88.6	70.9	NA	4x1.5 + 4x25	4x1.5 + 2(4x35)	4x1.5 + 2(4x10)	0.4	44(5.5)	592	702	712	80	DN100	
WP4-100-4	62	1740	216.3	108.0	86.5	NA	4x1.5 + 4x35	4x1.5 + 2(4x35)	4x1.5 + 2(4x10)	0.4	44(5.5)	604	714	724	80	DN100	
WP4-100-4	78	1740	240.7	120.3	96.3	NA	4x1.5 + 4x35	4x1.5 + 2(4x35)	4x1.5 + 2(4x16)	0.4	44(5.5)	620	730	740	80	DN100	
WP4-150-4	21.3	1740	90.5	45.2	36.1	4x1.5 + 4x25	4x1.5 + 4x10	4x1.5 + 2(4x35)	4x1.5 + 2(4x4)	0.4	44(5.5)	466	576	586	100	DN150	
WP4-150-4	25.3	1740	90.5	45.2	36.1	4x1.5 + 4x25	4x1.5 + 4x10	4x1.5 + 2(4x35)	4x1.5 + 2(4x4)	0.4	44(5.5)	476	586	596	100	DN150	
WP4-150-4	33.5	1740	121.1	60.6	48.5	4x1.5 + 4x35	4x1.5 + 4x16	4x1.5 + 2(4x35)	4x1.5 + 2(4x6)	0.4	44(5.5)	502	612	622	100	DN150	
WP4-150-4	42.5	1740	145.3	72.7	58	4x1.5 + 4x50	4x1.5 + 4x25	4x1.5 + 2(4x35)	4x1.5 + 2(4x10)	0.4	44(5.5)	553	663	673	100	DN150	
WP4-150-4	52	1740	177.2	88.6	70.9	NA	4x1.5 + 4x25	4x1.5 + 2(4x35)	4x1.5 + 2(4x10)	0.4	44(5.5)	596	706	716	100	DN150	
WP4-150-4	62	1740	216.3	108.0	86.5	NA	4x1.5 + 4x35	4x1.5 + 2(4x35)	4x1.5 + 2(4x10)	0.4	44(5.5)	608	718	728	100	DN150	
WP4-150-4	78	1740	240.7	120.3	96.3	NA	4x1.5 + 4x35	4x1.5 + 2(4x35)	4x1.5 + 2(4x16)	0.4	44(5.5)	624	734	744	100	DN150	
WP4-200-4	21.3	1740	90.5	45.2	36.1	4x1.5 + 4x25	4x1.5 + 4x10	4x1.5 + 2(4x35)	4x1.5 + 2(4x4)	0.4	44(5.5)	515	625	635	100	DN200	
WP4-200-4	25.3	1740	90.5	45.2	36.1	4x1.5 + 4x25	4x1.5 + 4x10	4x1.5 + 2(4x35)	4x1.5 + 2(4x4)	0.4	44(5.5)	525	635	645	100	DN200	
WP4-200-4	33.5	1740	121.1	60.6	48.5	4x1.5 + 4x35	4x1.5 + 4x16	4x1.5 + 2(4x35)	4x1.5 + 2(4x6)	0.4	44(5.5)	533	643	653	100	DN200	
WP4-200-4	42.5	1740	145.3	72.7	58	4x1.5 + 4x50	4x1.5 + 4x25	4x1.5 + 2(4x35)	4x1.5 + 2(4x10)	0.4	44(5.5)	583	693	703	100	DN200	
WP4-200-4	52	1740	177.2	88.6	70.9	NA	4x1.5 + 4x25	4x1.5 + 2(4x35)	4x1.5 + 2(4x10)	0.4	44(5.5)	626	736	746	100	DN200	
WP4-200-4	62	1740	216.3	108.0	86.5	NA	4x1.5 + 4x35	4x1.5 + 2(4x35)	4x1.5 + 2(4x10)	0.4	44(5.5)	638	748	758	100	DN200	
WP4-200-4	78	1740	240.7	120.3	96.3	NA	4x1.5 + 4x35	4x1.5 + 2(4x35)	4x1.5 + 2(4x16)	0.4	44(5.5)	654	764	774	100	DN200	
WP4-200-6	22	1170	4.9	88.4	44.2	40.1	4x1.5 + 4x25	4x1.5 + 4x6	4x1.5 + 2(4x35)	4x1.5 + 7x2.5	0.4	44(5.5)	533	643	653	100	DN200
WP4-200-6	26	1175	5.7	103.2	51.6	40.1	4x1.5 + 4x25	4x1.5 + 4x10	4x1.5 + 2(4x35)	4x1.5 + 2(4x4)	0.4	44(5.5)	566	676	686	100	DN200
WP4-200-6	35	1175	5.6	138.4	69.2	51.5	4x1.5 + 2(4x25)	4x1.5 + 4x16	4x1.5 + 2(4x35)	4x1.5 + 2(4x6)	0.4	44(5.5)	616	726	736	100	DN200

Type	kW P2	Rpm	start I (A)	I (A)			Cable DOL		Cable S/D		Oil	Coolant (w/o Cooling jacket)	Weight in kg Wet install	Weight in kg Dry install	Weight in kg Portable install	Throughlet in mm	Outlet flange
				230V	460V	575V	3x230V	3x400V	3x230V	3x400V							
WP4-200-6	44	1175	5.6	174.0	87.0	63.8	4x1.5 - 2(4x25)	4x1.5 - 4x25	4x1.5 - 2(4x35)	4x1.5 - 2(4x10)	0.4	44(5.5)	625	735	745	100	DN200
WP4-250-4	21.3	1740		90.5	45.2	36.1	4x1.5 - 4x25	4x1.5 - 4x10	4x1.5 - 2(4x35)	4x1.5 - 2(4x4)	0.4	44(5.5)	533	643	653	100	DN250
WP4-250-4	25.3	1740		90.5	45.2	36.1	4x1.5 - 4x25	4x1.5 - 4x10	4x1.5 - 2(4x35)	4x1.5 - 2(4x4)	0.4	44(5.5)	585	695	705	100	DN250
WP4-250-4	33.5	1740		121.1	60.6	48.5	4x1.5 - 4x35	4x1.5 - 4x16	4x1.5 - 2(4x35)	4x1.5 - 2(4x6)	0.4	44(5.5)	626	736	746	100	DN250
WP4-250-4	42.5	1740		145.3	72.7	58	4x1.5 - 4x50	4x1.5 - 4x25	4x1.5 - 2(4x35)	4x1.5 - 2(4x10)	0.4	44(5.5)	642	752	762	100	DN250
WP4-250-4	52	1740		177.2	88.6	70.9	NA	4x1.5 - 4x25	4x1.5 - 2(4x35)	4x1.5 - 2(4x10)	0.4	44(5.5)	668	778	788	100	DN250
WP4-250-4	62	1740		216.3	108.0	86.5	NA	4x1.5 - 4x35	4x1.5 - 2(4x35)	4x1.5 - 2(4x10)	0.4	44(5.5)	688	798	808	100	DN250
WP4-250-4	78	1740		240.7	120.3	96.3	NA	4x1.5 - 4x35	4x1.5 - 2(4x35)	4x1.5 - 2(4x16)	0.4	44(5.5)	751	861	871	100	DN250
WP4-250-6	22	1170	4.9	88.4	44.2	40.1	4x1.5 - 4x25	4x1.5 - 4x6	4x1.5 - 2(4x35)	4x1.5 - 7x2.5	0.4	44(5.5)	533	643	653	100	DN250
WP4-250-6	26	0	5.7	103.2	51.6	40.1	4x1.5 - 4x25	4x1.5 - 4x10	4x1.5 - 2(4x35)	4x1.5 - 2(4x4)	0.4	44(5.5)	566	676	686	100	DN250
WP4-250-6	35	1175	5.6	138.4	69.2	51.5	4x1.5 - 2(4x25)	4x1.5 - 4x16	4x1.5 - 2(4x35)	4x1.5 - 2(4x6)	0.4	44(5.5)	616	726	736	100	DN250
WP4-250-6	44	1175	5.6	174.0	87.0	63.8	4x1.5 - 2(4x25)	4x1.5 - 4x25	4x1.5 - 2(4x35)	4x1.5 - 2(4x10)	0.4	44(5.5)	625	735	745	100	DN250
WP4-300-6	22	1170	4.9	88.4	44.2	40.1	4x1.5 - 4x25	4x1.5 - 4x6	4x1.5 - 2(4x35)	4x1.5 - 7x2.5	0.4	44(5.5)	700	810	820	100	DN300
WP4-300-6	26	0	5.7	103.2	51.6	40.1	4x1.5 - 4x25	4x1.5 - 4x10	4x1.5 - 2(4x35)	4x1.5 - 2(4x4)	0.4	44(5.5)	733	843	853	100	DN300
WP4-300-6	35	1175	5.6	138.4	69.2	51.5	4x1.5 - 2(4x25)	4x1.5 - 4x16	4x1.5 - 2(4x35)	4x1.5 - 2(4x6)	0.4	44(5.5)	783	893	903	100	DN300
WP4-300-6	44	1175	5.6	174.0	87.0	63.8	4x1.5 - 2(4x25)	4x1.5 - 4x25	4x1.5 - 2(4x35)	4x1.5 - 2(4x10)	0.4	44(5.5)	792	902	912	100	DN300
WP4-300-6	54	1175	5.6	213.5	106.7	85.3	4x1.5 - 2(4x35)	4x1.5 - 4x25	4x1.5 - 2(4x35)	4x1.5 - 2(4x16)	0.4	44(5.5)	1200	1310	1320	100	DN300
WP4-300-8	17	875	4.9	70.6	35.3	28.4	4x1.5 - 4x16	4x1.5 - 4x4	4x1.5 - 2(4x35)	4x1.5 - 7x2.5	0.4	44(5.5)	710	820	830	100	DN300
WP4-300-8	22	875	4.9	91.3	45.7	36.6	4x1.5 - 4x25	4x1.5 - 4x10	4x1.5 - 2(4x35)	4x1.5 - 7x2.5	0.4	44(5.5)	710	820	830	100	DN300
WP5-150-4	86	1700		262.0	131.0	104.8	NA	4x1.5 - 4x50	NA	4x1.5 - 2(4x16)	0.4	134(14)	1187	1505	1561	93	DN150
WP5-150-4	104	1700		272.0	136.0	108.8	NA	4x1.5 - 4x50	NA	4x1.5 - 2(4x16)	0.4	118(14)	1254	1572	1628	93	DN150
WP5-150-4	127	1700		336.0	168.0	134.4	NA	4x1.5 - 4x70	NA	4x1.5 - 2(4x25)	0.4	118(14)	1282	1600	1656	93	DN150
WP5-150-4	152	1700		396.0	198.0	158.4	NA	4x1.5 - 2(4x35)	NA	4x1.5 - 2(4x25)	0.4	118(14)	1363	1681	1737	93	DN150
WP5-150-4	184	1700		480.0	240.0	192	NA	4x1.5 - 2(4x50)	NA	4x1.5 - 2(4x35)	0.4	118(14)	1345	1663	1719	93	DN150
WP5-150-4	230	1700		600.0	300.0	240	NA	4x1.5 - 2(4x70)	NA	4x1.5 - 2(4x70)	0.4	118(14)	1463	1781	1837	93	DN150
WP5-150-6	90	1170		242.0	121.0	96.8	NA	4x1.5 - 4x50	4x1.5 - 2(4x50)	4x1.5 - 2(4x16)	0.4	134(14)	1266	1584	1640	93	DN150
WP5-150-6	108	1170		284.0	142.0	113.6	NA	4x1.5 - 4x50	4x1.5 - 2(4x70)	4x1.5 - 2(4x16)	0.4	118(14)	1334	1652	1708	93	DN150
WP5-150-6	132	1170		348.0	174.0	139.2	NA	4x1.5 - 4x70	NA	4x1.5 - 2(4x25)	0.4	118(14)	1428	1746	1802	93	DN150
WP5-150-6	158	1170		410.0	205.0	164	NA	4x1.5 - 2(4x35)	NA	4x1.5 - 2(4x25)	0.4	118(14)	1476	1794	1850	93	DN150
WP5-150-6	192	1170		510.0	255.0	204	NA	4x1.5 - 2(4x50)	NA	4x1.5 - 2(4x35)	0.4	118(14)	1518	1836	1892	93	DN150
WP5-150-8	90	870		296.0	148.0	118.4	NA	4x1.5 - 4x50	4x1.5 - 2(4x70)	4x1.5 - 2(4x25)	0.4	134(14)	1201	1519	1575	93	DN150
WP5-150-8	108	870		362.0	181.0	144.8	NA	4x1.5 - 2(4x35)	NA	4x1.5 - 2(4x25)	0.4	118(14)	1249	1567	1623	93	DN150
WP5-150-8	132	870		440.0	220.0	176	NA	4x1.5 - 2(4x35)	NA	4x1.5 - 2(4x25)	0.4	118(14)	1421	1739	1795	93	DN150
WP5-150-8	158	870		490.0	245.0	196	NA	4x1.5 - 2(4x50)	NA	4x1.5 - 2(4x35)	0.4	118(14)	1499	1817	1873	130	DN150
WP5-200-4	86	1700		262.0	131.0	104.8	NA	4x1.5 - 4x50	4x1.5 - 2(4x50)	4x1.5 - 2(4x16)	0.4	134(14)	1276	1594	1650	130	DN200
WP5-200-4	104	1700		272.0	136.0	108.8	NA	4x1.5 - 4x50	4x1.5 - 2(4x50)	4x1.5 - 2(4x25)	0.4	118(14)	1343	1661	1717	130	DN200
WP5-200-4	127	1700		336.0	168.0	134.4	NA	4x1.5 - 4x70	4x1.5 - 2(4x70)	4x1.5 - 2(4x25)	0.4	118(14)	1371	1689	1745	130	DN200
WP5-200-4	152	1700		396.0	198.0	158.4	NA	4x1.5 - 2(4x35)	NA	4x1.5 - 2(4x25)	0.4	118(14)	1452	1770	1826	130	DN200
WP5-200-4	184	1700		480.0	240.0	192	NA	4x1.5 - 2(4x50)	NA	4x1.5 - 2(4x35)	0.4	118(14)	1434	1752	1808	130	DN200
WP5-200-4	230	1700		600.0	300.0	240	NA	4x1.5 - 2(4x70)	NA	4x1.5 - 2(4x70)	0.4	118(14)	1552	1870	1926	130	DN200
WP5-200-6	90	1170		242.0	121.0	96.8	NA	4x1.5 - 4x50	4x1.5 - 2(4x50)	4x1.5 - 2(4x16)	0.4	134(14)	1355	1673	1729	130	DN200
WP5-200-6	108	1170		284.0	142.0	113.6	NA	4x1.5 - 4x70	4x1.5 - 2(4x70)	4x1.5 - 2(4x16)	0.4	118(14)	1423	1741	1797	130	DN200
WP5-200-6	132	1170		348.0	174.0	139.2	NA	4x1.5 - 4x70	NA	4x1.5 - 2(4x25)	0.4	118(14)	1517	1835	1891	130	DN200
WP5-200-6	158	1170		410.0	205.0	164	NA	4x1.5 - 2(4x35)	NA	4x1.5 - 2(4x25)	0.4	118(14)	1565	1883	1939	130	DN200
WP5-200-6	192	1170		510.0	255.0	204	NA	4x1.5 - 2(4x50)	NA	4x1.5 - 2(4x35)	0.4	118(14)	1607	1925	1981	130	DN200
WP5-200-8	90	870		296.0	148.0	118.4	NA	4x1.5 - 4x70	4x1.5 - 2(4x70)	4x1.5 - 2(4x25)	0.4	134(14)	1290	1608	1664	130	DN200
WP5-200-8	108	870		362.0	181.0	144.8	NA	4x1.5 - 2(4x35)	NA	4x1.5 - 2(4x25)	0.4	118(14)	1338	1656	1712	130	DN200
WP5-200-8	132	870		440.0	220.0	176	NA	4x1.5 - 2(4x35)	NA	4x1.5 - 2(4x25)	0.4	118(14)	1510	1828	1884	130	DN200
WP5-200-8	158	870		490.0	245.0	196	NA	4x1.5 - 2(4x50)	NA	4x1.5 - 2(4x35)	0.4	118(14)	1588	1906	1962	130	DN250
WP5-250-4	86	1700		262.0	131.0	104.8	NA	4x1.5 - 4x50	4x1.5 - 2(4x50)	4x1.5 - 2(4x16)	0.4	134(14)	1295	1613	1669	130	DN250
WP5-250-4	104	1700		272.0	136.0	108.8	NA	4x1.5 - 4x50	4x1.5 - 2(4x50)	4x1.5 - 2(4x16)	0.4	118(14)	1362	1680	1736	130	DN250
WP5-250-4	127	1700		336.0	168.0	134.4	NA	4x1.5 - 4x70	4x1.5 - 2(4x70)	4x1.5 - 2(4x25)	0.4	118(14)	1390	1708	1764	130	DN250
WP5-250-4	152	1700		396.0	198.0	158.4	NA	4x1.5 - 2(4x35)	NA	4x1.5 - 2(4x25)	0.4	118(14)	1471	1789	1845	130	DN250
WP5-250-4	184	1700		480.0	240.0	192	NA	4x1.5 - 2(4x50)	NA	4x1.5 - 2(4x35)	0.4	118(14)	1453	1771	1827	130	DN250
WP5-250-4	230	1700		600.0	300.0	240	NA	4x1.5 - 2(4x70)	NA	4x1.5 - 2(4x70)	0.4	118(14)	1571	1889	1945	130	DN250
WP5-250-6	90	1170		242.0	121.0	96.8	NA	4x1.5 - 4x50	4x1.5 - 2(4x50)	4x1.5 - 2(4x16)	0.4	134(14)	1374	1692	1748	130	DN250
WP5-250-6	108	1170		284.0	142.0	113.6	NA	4x1.5 - 4x70	4x1.5 - 2(4x50)	4x1.5 - 2(4x16)	0.4	118(14)	1442	1760	1816	130	DN250
WP5-250-6	132	1170		348.0	174.0	139.2	NA	4x1.5 - 4x70	NA	4x1.5 - 2(4x25)	0.4	118(14)	1536	1854	1910	130	DN250

Type	kW P2	Rpm	I (A)			Cable DOL			Cable S/D		Oil	Coolant (w/o Cooling jacket)	Weight in kg Wet install	Weight in kg Dry install	Weight in kg Portable install	Throughlet in mm	Outlet flange
			start I (A)	230V	460V	575V	3x230V	3x400V	3x230V	3x400V							
WPS-250-6	158	1170	410.0	205.0	164	NA	4x1.5 - 2(4x35)	NA	4x1.5 - 2(4x25)	0.4	118(14)	1584	1902	1958	130	DN250	
WPS-250-6	192	1170	510.0	255.0	204	NA	4x1.5 - 2(4x50)	NA	4x1.5 - 2(4x35)	0.4	118(14)	1626	1944	2000	130	DN250	
WPS-250-8	90	870	296.0	148.0	118.4	NA	4x1.5 - 4x70	4x1.5 - 2(4x70)	4x1.5 - 2(4x16)	0.4	134(14)	1309	1627	1683	130	DN250	
WPS-250-8	108	870	362.0	181.0	144.8	NA	4x1.5 - 2(4x35)	NA	4x1.5 - 2(4x25)	0.4	118(14)	1357	1675	1731	130	DN250	
WPS-250-8	132	870	440.0	220.0	176	NA	4x1.5 - 2(4x35)	NA	4x1.5 - 2(4x25)	0.4	118(14)	1529	1847	1903	130	DN250	
WPS-250-8	158	870	490.0	245.0	196	NA	4x1.5 - 2(4x50)	NA	4x1.5 - 2(4x35)	0.4	118(14)	1607	1925	1981	130	DN250	
WPS-300-4	86	1700	262.0	131.0	104.8	NA	4x1.5 - 4x50	4x1.5 - 2(4x50)	4x1.5 - 2(4x16)	0.4	134(14)	1329	1647	1703	130	DN300	
WPS-300-4	104	1700	272.0	136.0	108.8	NA	4x1.5 - 4x50	4x1.5 - 2(4x50)	4x1.5 - 2(4x16)	0.4	118(14)	1396	1714	1770	130	DN300	
WPS-300-4	127	1700	336.0	168.0	134.4	NA	4x1.5 - 4x70	4x1.5 - 2(4x70)	4x1.5 - 2(4x25)	0.4	118(14)	1424	1742	1798	130	DN300	
WPS-300-4	152	1700	396.0	198.0	158.4	NA	4x1.5 - 2(4x35)	NA	4x1.5 - 2(4x25)	0.4	118(14)	1505	1823	1879	130	DN300	
WPS-300-4	184	1700	480.0	240.0	192	NA	4x1.5 - 2(4x50)	NA	4x1.5 - 2(4x35)	0.4	118(14)	1487	1805	1861	130	DN300	
WPS-300-4	230	1700	600.0	300.0	240	NA	4x1.5 - 2(4x70)	NA	4x1.5 - 2(4x70)	0.4	118(14)	1605	1923	1979	130	DN300	
WPS-300-6	90	1170	242.0	121.0	96.8	NA	4x1.5 - 4x50	4x1.5 - 2(4x50)	4x1.5 - 2(4x16)	0.4	134(14)	1408	1726	1782	130	DN300	
WPS-300-6	108	1170	284.0	142.0	113.6	NA	4x1.5 - 4x70	4x1.5 - 2(4x50)	4x1.5 - 2(4x16)	0.4	118(14)	1476	1794	1850	130	DN300	
WPS-300-6	132	1170	348.0	174.0	139.2	NA	4x1.5 - 4x70	NA	4x1.5 - 2(4x25)	0.4	118(14)	1570	1888	1944	130	DN300	
WPS-300-6	158	1170	410.0	205.0	164	NA	4x1.5 - 2(4x50)	NA	4x1.5 - 2(4x25)	0.4	118(14)	1618	1936	1992	130	DN300	
WPS-300-6	192	1170	510.0	255.0	204	NA	4x1.5 - 2(4x50)	NA	4x1.5 - 2(4x35)	0.4	118(14)	1660	1978	2034	130	DN300	
WPS-300-8	90	870	296.0	148.0	118.4	NA	4x1.5 - 4x70	4x1.5 - 2(4x70)	4x1.5 - 2(4x16)	0.4	134(14)	1343	1661	1717	130	DN300	
WPS-300-8	108	870	362.0	181.0	144.8	NA	4x1.5 - 2(4x35)	NA	4x1.5 - 2(4x25)	0.4	118(14)	1391	1709	1765	130	DN300	
WPS-300-8	132	870	440.0	220.0	176	NA	4x1.5 - 2(4x35)	NA	4x1.5 - 2(4x25)	0.4	118(14)	1563	1881	1937	130	DN300	
WPS-300-8	158	870	490.0	245.0	196	NA	4x1.5 - 2(4x50)	NA	4x1.5 - 2(4x35)	0.4	118(14)	1641	1959	2015	130	DN300	
WPS-350-4	86	1700	262.0	131.0	104.8	NA	4x1.5 - 4x50	4x1.5 - 2(4x50)	4x1.5 - 2(4x16)	0.4	134(14)	1424	1742	1798	130	DN350	
WPS-350-4	104	1700	272.0	136.0	108.8	NA	4x1.5 - 4x50	4x1.5 - 2(4x50)	4x1.5 - 2(4x16)	0.4	118(14)	1491	1809	1865	130	DN350	
WPS-350-4	127	1700	336.0	168.0	134.4	NA	4x1.5 - 4x70	4x1.5 - 2(4x70)	4x1.5 - 2(4x25)	0.4	118(14)	1519	1837	1893	130	DN350	
WPS-350-4	152	1700	396.0	198.0	158.4	NA	4x1.5 - 2(4x35)	NA	4x1.5 - 2(4x25)	0.4	118(14)	1600	1918	1974	130	DN350	
WPS-350-4	184	1700	480.0	240.0	192	NA	4x1.5 - 2(4x50)	NA	4x1.5 - 2(4x35)	0.4	118(14)	1582	1900	1956	130	DN350	
WPS-350-4	230	1700	600.0	300.0	240	NA	4x1.5 - 2(4x70)	NA	4x1.5 - 2(4x70)	0.4	118(14)	1700	2018	2074	130	DN350	
WPS-350-6	90	1170	242.0	121.0	96.8	NA	4x1.5 - 4x50	4x1.5 - 2(4x50)	4x1.5 - 2(4x16)	0.4	134(14)	1503	1821	1877	130	DN350	
WPS-350-6	108	1170	284.0	142.0	113.6	NA	4x1.5 - 4x70	4x1.5 - 2(4x70)	4x1.5 - 2(4x16)	0.4	118(14)	1571	1889	1945	130	DN350	
WPS-350-6	132	1170	348.0	174.0	139.2	NA	4x1.5 - 4x70	NA	4x1.5 - 2(4x25)	0.4	118(14)	1665	1983	2039	130	DN350	
WPS-350-6	158	1170	410.0	205.0	164	NA	4x1.5 - 2(4x35)	NA	4x1.5 - 2(4x25)	0.4	118(14)	1713	2031	2087	130	DN350	
WPS-350-6	192	1170	510.0	255.0	204	NA	4x1.5 - 2(4x50)	NA	4x1.5 - 2(4x35)	0.4	118(14)	1755	2073	2129	130	DN350	
WPS-350-8	90	870	296.0	148.0	118.4	NA	4x1.5 - 4x70	4x1.5 - 2(4x70)	4x1.5 - 2(4x16)	0.4	134(14)	1438	1756	1812	130	DN350	
WPS-350-8	108	870	362.0	181.0	144.8	NA	4x1.5 - 2(4x35)	NA	4x1.5 - 2(4x25)	0.4	118(14)	1486	1804	1860	130	DN350	
WPS-350-8	132	870	440.0	220.0	176	NA	4x1.5 - 2(4x35)	NA	4x1.5 - 2(4x25)	0.4	118(14)	1658	1976	2032	130	DN350	
WPS-350-8	158	870	490.0	245.0	196	NA	4x1.5 - 2(4x50)	NA	4x1.5 - 2(4x35)	0.4	118(14)	1736	2054	2110	130	DN350	
WPS-400-4	86	1700	262.0	131.0	104.8	NA	4x1.5 - 4x70	4x1.5 - 2(4x50)	4x1.5 - 2(4x16)	0.4	134(14)	1684	2002	2058	145	DN400	
WPS-400-4	104	1700	272.0	136.0	108.8	NA	4x1.5 - 4x50	4x1.5 - 2(4x50)	4x1.5 - 2(4x16)	0.4	118(14)	1751	2069	2125	145	DN400	
WPS-400-4	127	1700	336.0	168.0	134.4	NA	4x1.5 - 4x70	4x1.5 - 2(4x70)	4x1.5 - 2(4x25)	0.4	118(14)	1779	2097	2153	145	DN400	
WPS-400-4	152	1700	396.0	198.0	158.4	NA	4x1.5 - 2(4x35)	NA	4x1.5 - 2(4x25)	0.4	118(14)	1860	2178	2234	145	DN400	
WPS-400-4	184	1700	480.0	240.0	192	NA	4x1.5 - 2(4x50)	NA	4x1.5 - 2(4x35)	0.4	118(14)	1842	2160	2216	145	DN400	
WPS-400-4	230	1700	600.0	300.0	240	NA	4x1.5 - 2(4x70)	NA	4x1.5 - 2(4x70)	0.4	118(14)	1960	2278	2334	145	DN400	
WPS-400-6	90	1170	242.0	121.0	96.8	NA	4x1.5 - 4x50	4x1.5 - 2(4x50)	4x1.5 - 2(4x16)	0.4	134(14)	1763	2081	2137	145	DN400	
WPS-400-6	108	1170	284.0	142.0	113.6	NA	4x1.5 - 4x70	4x1.5 - 2(4x70)	4x1.5 - 2(4x16)	0.4	118(14)	1831	2149	2205	145	DN400	
WPS-400-6	132	1170	348.0	174.0	139.2	NA	4x1.5 - 4x70	NA	4x1.5 - 2(4x25)	0.4	118(14)	1925	2243	2299	145	DN400	
WPS-400-6	158	1170	410.0	205.0	164	NA	4x1.5 - 2(4x35)	NA	4x1.5 - 2(4x25)	0.4	118(14)	1973	2291	2347	145	DN400	
WPS-400-6	192	1170	510.0	255.0	204	NA	4x1.5 - 2(4x50)	NA	4x1.5 - 2(4x35)	0.4	118(14)	2015	2333	2389	145	DN400	
WPS-400-8	90	870	296.0	148.0	118.4	NA	4x1.5 - 4x70	4x1.5 - 2(4x70)	4x1.5 - 2(4x16)	0.4	134(14)	1698	2016	2072	145	DN400	
WPS-400-8	108	870	362.0	181.0	144.8	NA	4x1.5 - 2(4x35)	NA	4x1.5 - 2(4x25)	0.4	118(14)	1746	2064	2120	145	DN400	
WPS-400-8	132	870	440.0	220.0	176	NA	4x1.5 - 2(4x35)	NA	4x1.5 - 2(4x25)	0.4	118(14)	1918	2236	2292	145	DN400	
WPS-400-8	158	870	490.0	245.0	196	NA	4x1.5 - 2(4x50)	NA	4x1.5 - 2(4x35)	0.4	118(14)	1996	2314	2370	145	DN400	

Overensstemmelseserklæring EC declaration of conformity / Konformitätserklärung

Producent / Manufacturer / Hersteller

DanPumps A/S
Niels Bohrs Vej 10
DK-6100 Haderslev
Tel: +45 69 15 93 94

Repræsentant / Representative / Repräsentative

**Erklærer på eget ansvar, at følgende produkter /
Declare under our sole responsibility that the products /
Erklärt eigenverantwortlich, daß die Produkte**

Spildevandspumpe / Wastewater pump / Abwasserpumpe
Series: S-WP series
Models: S-WP0, S-WP1, S-WP2, S-WP3, S-WP4 and S-WP5

**Som er omfattet af denne erklæring, er i overensstemmelse med følgende standarder /
To which this declaration relates are in conformity with the following standards /
Auf die sich diese Erklärung bezieht, den folgenden normativen Dokumenten entsprechen**

Maskindirektivet / Machinery directive / Maschinenrichtlinie
EMC-Direktivet / EMC-Directive / EMV-Richtlinie
Lavspændingsdirektivet / Low Voltage Directive / Niederspannungsrichtlinie

2006/42/EU Appendix II A
EMC 2014/30/EU
LVD 2014/35/EU

November 2023

A handwritten signature in blue ink, appearing to read "Dennis Hansen".

Dennis Hansen
Managing Director



About DanPumps A/S

Established in 2013, DanPumps A/S has been dedicated to providing pumping solutions to utility companies and industries. In November 2023, DanPumps once again became an independent company, concluding a successful period under SonFlow's guidance. Today, our unwavering commitment is directed towards the development and manufacturing of quality pumps.

Wide Range of Pumps

Our pumps range at DanPumps A/S is continually evolving, and our ability to deliver customized solutions makes us one of the most flexible and competitive suppliers in the market.

Our pump range is the result of high efficiency, intelligent design, and practical features. These qualities are combined to create user-friendly pumps with a long lifespan. We provide pumps for a wide range of applications, including wastewater, marine, industrial, and sanitary purposes.

