

Free Flow Heat Exchanger SFF100 Series

SFF101



SonFlow offers a wide range of Free Flow Plate Heat Exchangers for various market segments. Our SFF100 series is ideal for industries that handle liquids with fibers and solid particles, such as fruit juice and sugar production. Our plate heat exchangers ensure gentle treatment, even distribution of the medium, and high product quality.

Typical applications:

- Dairy/food/beverage industry
- Sugar industry
- Biogas industry
- Wastewater industry
- Pulp and paper industry
- Mining industry

Features:

Every detail is carefully designed to ensure optimal performance, reduced maintenance costs and decreased downtime:

- Compact design
- Gentle product handling
- Suitable for products with solid particles
- Design pressure up to 10 bar

- Operating temperature: up to 180 °C
- Fixed bolt head
- Lifting lug
- Lining
- Lock washer

Benefits:

- Designed for CIP cleaning
- Easy assembly
- Cost-effective
- Designed to combat fouling
- Clog resistant
- The inlet area is designed for optimal distribution and flow across the plate
- No dead spots on the plate

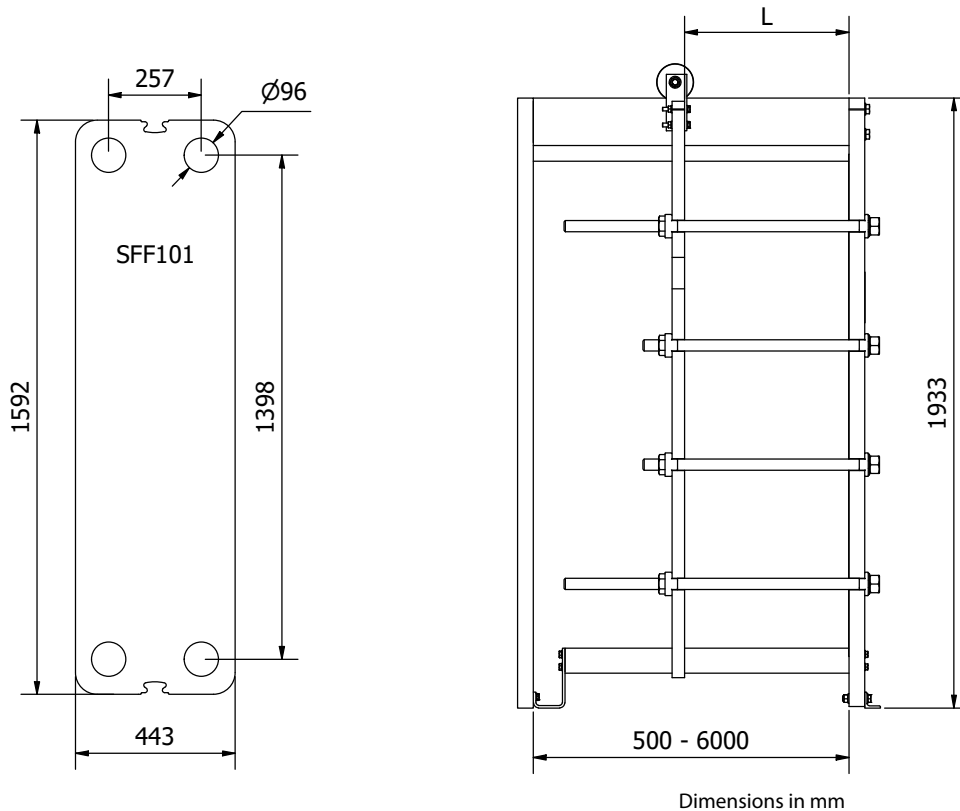

Design pressure:

- Painted frames: 1.0 MPa (145 PSI)
- Stainless steel frame: 1.0 MPa (145 PSI)
- Max. differential pressure: 6 bar

Construction standards:

- EN13445
- ASME sec VIII, Div. 1

Frame:

- Painted frame, RAL 5010 (available in other colours)

Connections:

- DN 100/4" flange in carbon steel or rubber lined
- DN 80/3" dairy pipes or union
- According to all known standards

Plate material:

- AISI 304/316 and titanium
- Other materials available on request

Gaskets:

- Glued gasket
- Materials: NBR, EPDM and Viton
- Other materials available on request

Accessories:

- Drip tray
- Insulation jackets
- Safety cover
- Assembling spanner
- Foundation feet